

Elevating your World.

► Technical Catalogue



DOPPLER

Elevating your World.



Welcome.

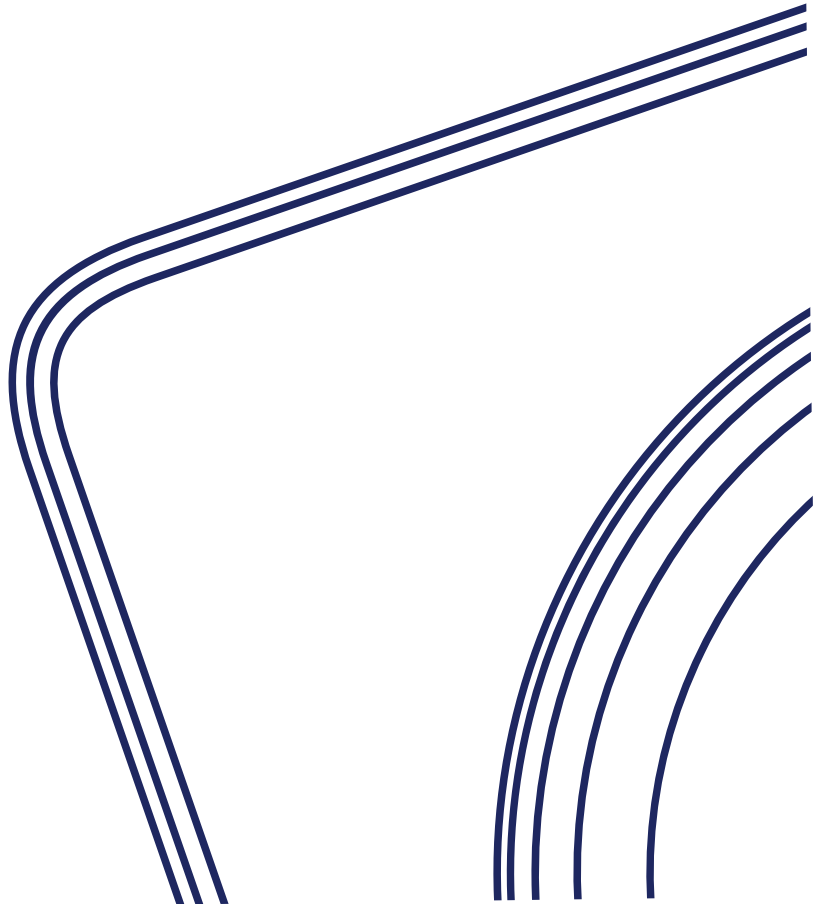

Index.

Technical specifications	4-37
▶ Eco 2i	6-9
▶ Traction MR	7-9
▶ Eco 2is Traction MRL	10
▶ Traction MR/MRL Cargo / Car lift	11
▶ Traction RC	12-17
▶ Focus	18-21
▶ ELLI EN81-41	22-23
▶ ELLI 2006/42	24-25
▶ ELLI EN 81-20	26-27
▶ Hydraulic MR/MRL Passenger Lift	28-29
▶ Doppler Hydraulic Power units MR/MRL/TMRL	30-31
▶ Twin Jack Direct [1:1] Acting Hydraulic Lift	32-33
▶ Twin Jack Direct [2:1] Acting Hydraulic Lift	34-35
▶ Double ELLI Car Lift	36-37
▶ Dumbwaiter	38-39
Modernization & lift components	40-51
▶ Modernization Kit	42
▶ Wireless Monitoring	43
▶ Electrical	44-45
▶ DOPPLER electric Movable Stop Folding Buffer	46
▶ DOPPLER electric Movable Stop Moving Buffer	47
▶ DOPPLER Car Aprons	48
▶ DOPPLER Car Balustrades	49
▶ DOPPLER Pit Ladder	50
▶ DOPPLER Firefighting cabin roof and false ceiling	51



Escalators & Moving walks 52-61

- ▶ DHS 200-30 K Commercial Escalators 58
- ▶ DHS 200-30 Public Heavy Duty 59
- ▶ DHS 300 Moving Walk 10° - 12° 60
- ▶ DHS 300 Moving Walk 0° 61

Parking systems 62-67

- ▶ DCS-2D/2P 64
- ▶ DP-2I/2P 65
- ▶ DCS-2DL 66
- ▶ DPS-xRyC 67

Robotic parking systems 68-69

Inclined lifts 70-71

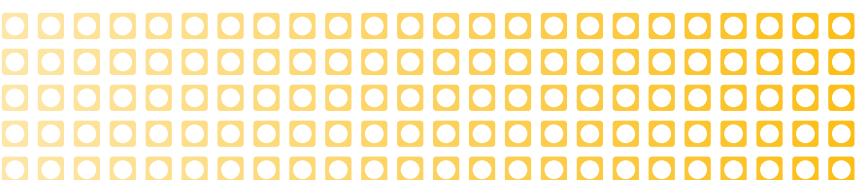

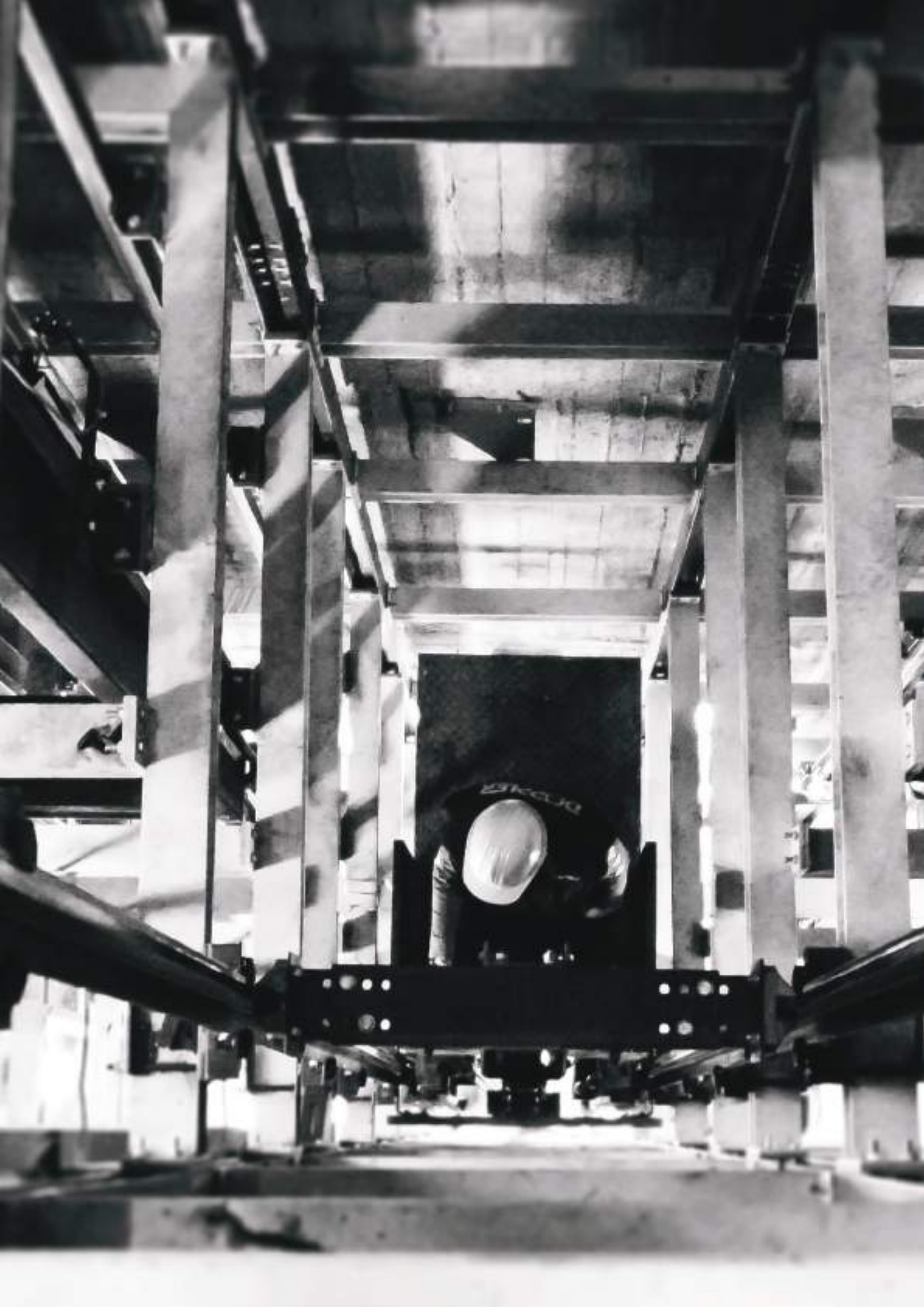

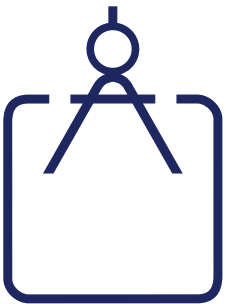

Technical Specifications.

Take a Look Inside!

DOPPLER offers a comprehensive range of elevator solutions designed to meet vertical transportation needs.

We have the right application for every kind of building either residential or commercial. We design and manufacture products keeping high quality and safety standards.

Our product range comprises both traction and hydraulic lifts for the transportation of passengers, cars as well as small and heavy freight.

Eco 2i Traction MRL [2:1].

Features:

- ▶ Speed up to 2,5m/sec
- ▶ Automatic emergency operation in case of power failure as a standard
- ▶ VVVF Drive System
- ▶ Smooth operation
- ▶ Conformity with EN81-20/50, EN81-21
- ▶ Compliance with Directive 2014/33/EU

Use:



Passenger Lifts.



Panoramic Lifts.



Hospital Lifts.



High Rise Buildings.



Hotels.



Shopping Malls.



Residential.



Traction MR [2:1].

Features:

- ▶ Speed up to 2,5m/sec
- ▶ Travel up to 100m
- ▶ Automatic emergency operation in case of power failure as a standard
- ▶ Conformity with EN8-20/50, EN81-21
- ▶ Compliance with Directive 2014/33/EU

Use:



Passenger Lifts.



Panoramic Lifts.



Hospital Lifts.



High Rise Buildings.



Hotels.



Shopping Malls.



Residential.



Specifications ECO 2i / Traction MR 1 m/s (2:1)

Max Capacity:	300 kg	450 kg	630 kg	1000 kg	1000 kg	1600 kg	2000 kg
Min PIT EN81-20:	1000mm	1000mm	1000mm	1000mm	1000mm	1150mm	1150mm
Min PIT EN81-21:	600mm*	600mm*	600mm*	600mm*	600mm*	700mm*	700mm*
Min PIT:	600mm*	600mm*	600mm*	600mm*	600mm*	700mm*	700mm*
Min. Headroom EN81-20:	3350mm	3350mm	3350mm	3350mm	3350mm	3750mm	3750mm
Min. Headroom EN81-21:	x	2800mm	2800mm	2800mm	2800mm	3000mm	3000mm
Min. Headroom ⁽¹⁾:	2800mm	2800mm	2800mm	2800mm	2800mm	3000mm	3000mm
Car guide Rails:	T70x65x9	T70x65x9	T70x65x9	T82x68x09	T82x68x09	T89x62x16	T114x89x16
CW guide Rails:	T50x50x5	T50x50x5	T50x50x5	T50x50x5	T50x50x5	T70x65x9	T70x65x9
Travel:	30000mm**	30000mm**	30000mm**	30000mm**	30000mm**	30000mm**	30000mm**
Machine Pulley:	Φ200	Φ210	Φ240	Φ240	Φ320	Φ320	Φ320
Standard Shaft:	1500x1350	1600x1600	1700x1750	1700x2450	1750x2500	2150x2800	2500x2800
Standard Cabin:	900x1000	1000x1250	1100x1400	1100x2100	1100x2100	1450x2400	1750x2400
Standard Door:	700mm 2PT	800mm 2PT	900mm 2PT	900mm 2PT	900mm 2PT	1200mm 2PT	1200mm 2PT
Standard Cabinet:	400X200X2230mm	400X200X2230mm	400X200X2230mm	400X200X2230mm	400X200X2230mm	400X200X2230mm	400X200X2230mm

*For travel more than 30000mm, a compensation chain is added and the pit depth must be ≥ 1000mm.

**Max Travel without compensation chain 30000mm. Max Travel with compensation chain 100000mm

***For Internal Car height 2100mm

⁽¹⁾Beyond EN81-20/50

Specifications ECO 2i / Traction MR 1.6 m/s (2:1)

Max Capacity:	300 kg	450 kg	630 kg	1000 kg	1000 kg	1600 kg	2000 kg
Min PIT EN81-20:	1150mm	1150mm	1150mm	1150mm	1150mm	1300mm	1300mm
Min PIT EN81-21:	1050mm	1050mm	1050mm	1050mm	1050mm	1050mm	1050mm
Min PIT ⁽¹⁾:	950mm*	950mm*	950mm*	950mm*	950mm*	950mm*	950mm*
Min. Headroom EN81-20:	3550mm	3550mm	3550mm	3550mm	3550mm	3950mm	3950mm
Min. Headroom EN81-21:	x	3000mm	3000mm	3000mm	3000mm	3200mm	3200mm
Min. Headroom ⁽¹⁾:	3000mm	3000mm	3000mm	3000mm	3000mm	3200mm	3200mm
Car guide Rails:	T70x65x9	T70x65x9	T70x65x9	T82x68x09	T82x68x09	T89x62x16	T114x89x16
CW guide Rails:	T50x50x5	T50x50x5	T50x50x5	T50x50x5	T50x50x5	T70x65x9	T70x65x9
Travel:	30000mm**	30000mm**	30000mm**	30000mm**	30000mm**	30000mm**	30000mm**
Machine Pulley:	Φ200	Φ210	Φ240	Φ240	Φ320	Φ320	Φ320
Standard Shaft:	1500x1350	1600x1600	1700x1750	1700x2450	1750x2500	2150x2800	2500x2800
Standard Cabin:	900x1000	1000x1250	1100x1400	1100x2100	1100x2100	1450x2400	1750x2400
Standard Door:	700mm 2PT	800mm 2PT	900mm 2PT	900mm 2PT	900mm 2PT	1200mm 2PT	1200mm 2PT
Standard Cabinet:	400X200X2230mm	400X200X2230mm	400X200X2230mm	400X200X2230mm	400X200X2230mm	400X200X2230mm	400X200X2230mm

*For travel more than 30000mm, a compensation chain is added and the pit depth must be ≥ 1000mm.

**Max Travel without compensation chain 30000mm. Max Travel with compensation chain 100000mm

***For Internal Car height 2100mm

⁽¹⁾Beyond EN81-20/50

Specifications ECO 2i / Traction MR 2m/s (2:1)

Max Capacity:	300 kg	450 kg	630 kg	1000 kg	1600 kg	2000 kg
Min PIT EN81-20:	1350mm	1350mm	1350mm	1350mm	1500mm	1500mm
Min PIT EN81-21:	1200mm	1200mm	1200mm	1200mm	1300mm	1300mm
Min PIT ⁽¹⁾:	1200*mm	1200*mm	1200*mm	1200*mm	1300*mm	1300*mm
Min. Headroom EN81-20:	4100mm	4100mm	4100mm	4100mm	4100mm	4100mm
"Min. Headroom EN81-21:"	x	3300mm	3300mm	3300mm	3300mm	3300mm
Min. Headroom ⁽¹⁾:	3100mm	3100mm	3100mm	3100mm	3300mm	3300mm
Car guide Rails:	T70x65x9	T70x65x9	T70x65x9	T82x68x09	T89x62x16	T114x89x16
CW guide Rails:	T50x50x5	T50x50x5	T50x50x5	T50x50x5	T70x65x9	T70x65x9
Travel:	30000mm**	30000mm**	30000mm**	30000mm**	30000mm**	30000mm**
Machine Pulley:	Φ320	Φ320	Φ320	Φ400	Φ400	Φ400
Standard Shaft:	1600x1400	1700x1650	1800x1800	1900x2500	2250x2800	2550x2800
Standard Cabin:	900x1000	1000x1250	1100x1400	1100x2100	1450x2400	1750x2400
Standard Door:	700mm 2PT	800mm 2PT	900mm 2PT	900mm 2PT	1200mm 2PT	1200mm 2PT
Standard Cabinet:	400X200X2230mm	400X200X2230mm	400X200X2230mm	400X200X2230mm	400X200X2230mm	400X200X2230mm

*For travel more than 30000mm, a compensation chain is added and the pit depth must be ≥ 1000mm.

**Max Travel without compensation chain 30000mm. Max Travel with compensation chain 100000mm

***For Internal Car height 2100mm

⁽¹⁾Beyond EN81-20/50

Specifications ECO 2i / Traction MR 2.5m/s (2:1)

Max Capacity:	300 kg	450 kg	630 kg	1000 kg	1600 kg	2000 kg
Min PIT EN81-20:	1600mm	1600mm	1600mm	1600mm	1700mm	1700mm
Min PIT EN81-21:	1600mm	1600mm	1600mm	1600mm	1700mm	1700mm
Min PIT ⁽¹⁾:	1600*mm	1600*mm	1600*mm	1600*mm	1700*mm	1700*mm
Min. Headroom EN81-20:	4400mm	4400mm	4400mm	4400mm	4400mm	4400mm
Min. Headroom EN81-21:	x	3500mm	3500mm	3500mm	3500mm	3500mm
Min. Headroom ⁽¹⁾:	3500mm	3500mm	3500mm	3500mm	3500mm	3500mm
Car guide Rails:	T70x65x9	T70x65x9	T70x65x9	T82x68x09	T89x62x16	T114x89x16
CW guide Rails:	T50x50x5	T50x50x5	T50x50x5	T50x50x5	T70x65x9	T70x65x9
Travel:	30000mm**	30000mm**	30000mm**	30000mm**	30000mm**	30000mm**
Machine Pulley:	Φ320	Φ320	Φ320	Φ400	Φ400	Φ400
Standard Shaft:	1600x1400	1700x1650	1800x1800	1900x2500	2250x2800	2550x2800
Standard Cabin:	900x1000	1000x1250	1100x1400	1100x2100	1450x2400	1750x2400
Standard Door:	700mm 2PT	800mm 2PT	900mm 2PT	900mm 2PT	1200mm 2PT	1200mm 2PT
Standard Cabinet:	400X200X2230mm	400X200X2230mm	400X200X2230mm	400X200X2230mm	400X200X2230mm	400X200X2230mm

*For travel more than 30000mm, a compensation chain is added and the pit depth must be ≥ 1000mm.

**Max Travel without compensation chain 30000mm. Max Travel with compensation chain 100000mm

***For Internal Car height 2100mm

⁽¹⁾Beyond EN81-20/50

Eco 2is Traction MRL [2:1].

Features:

- ▶ Speed up to 1m/sec
- ▶ Automatic emergency operation in case of power failure as a standard
- ▶ VVVF Drive System
- ▶ Smooth operation
- ▶ Conformity with EN81-20/50, EN81-21
- ▶ Compliance with Directive 2014/33/EU

Use:



Passenger Lifts.



Panoramic Lifts.



Hospital Lifts.



High Rise Buildings.



Hotels.



Shopping Malls.



Residential.



Specifications

Max Capacity	300kg	450kg	630kg	1.000kg
Min PIT (EN81-20)	1.000mm	1.000mm	1.000mm	1.000mm
Min PIT (EN81-21)	400mm ⁽¹⁾	400mm ⁽¹⁾	400mm ⁽¹⁾	400mm ⁽¹⁾
Min. Headroom EN81-20	3.600mm ⁽²⁾	3.600mm ⁽²⁾	3.350mm ⁽²⁾	3.350mm ⁽²⁾
Min. Headroom EN81-21	X	3.300mm ⁽²⁾	3.300mm ⁽²⁾	3.300mm ⁽²⁾
Travel	30.000mm ⁽³⁾	30.000mm ⁽³⁾	30.000mm ⁽³⁾	30.000mm ⁽³⁾
Standard Shaft	1.440X1.350	1.540X1.600 ⁽⁴⁾	1.640X1.750 ⁽⁴⁾	1.640X2.450
Standard Cabin	900X1.000	1.000X1.250	1.100X1.400	1.100X2.100
Standard Door	700mm 2PT	800mm 2PT	900mm 2PT	900mm 2PT
Standard Cabinet:	400X200X2230mm	400X200X2230mm	400X200X2230mm	400X200X2230mm

⁽¹⁾For travel more than 30000mm, a compensation chain is added and the pit depth must be \geq 1000mm

⁽²⁾For Internal Car height 2100mm

⁽³⁾Max Travel without compensation chain 30000mm. Max Travel with compensation chain 100000mm

⁽⁴⁾For lifts according to EN81-70 (DDA) the shaft must be 60mm wider

Traction MR/MRL Cargo / Car lift.

Features:

- ▶ Speed up to 1m/sec
- ▶ Automatic emergency operation in case of power failure as a standard
- ▶ Improved leveling accuracy
- ▶ Smooth Operation
- ▶ VVVF Drive System
- ▶ Conformity with EN 81-20/50, EN 81-21
- ▶ Compliance with Directive 2014/33/EU

Use:



Specifications					
Lift Type	ECO 2 Car Lift 1m/s (4:1) ⁽²⁾	ECO 2 Cargo 1m/s (2:1)	ECO 2 Cargo Lift 1m/s (4:1)		
Max. Capacity	3.000kg -5.000kg	2.500kg	3.000Kg	4.000Kg	5.000Kg
Min. PIT (EN81-20)	x	1.000mm	1.750mm	1.750mm	1.750mm
Min. PIT (EN81-21)	x	900mm	1.500mm	1.500mm	1.500mm
Min. PIT ⁽²⁾	1.500mm	850mm	1.450mm	1.450mm	1.450mm
Min. Headroom (EN81-20)	x	4.200mm	4.300mm	4.300mm	4.300mm
Min. Headroom (EN81-21)	x	3.850mm	4.150mm	4.150mm	4.150mm
Min. Headroom ⁽²⁾	4.150mm	3.850mm	4.150mm	4.150mm	4.150mm
Travel	30.000mm	30.000mm	30.000mm	30.000mm	30.000mm
Standard Shaft	3.800x6.600	2.600x3.100	2.650x3.600	2.800x4.200	3.200x4.200
Standard Cabin	3.000x6.000	1.800x2.700	1.850x3.100	2.000x3.700	2.400x3.700
Standard Door	2.500mm 4PC ⁽¹⁾	1.600mm 4PC	1.700mm 6PC	1.800mm 6PC	2.100mm 6PC
Standard Cabinet:	400X200X2230mm	400X200X2230mm	400X200X2230mm	400X200X2230mm	400X200X2230mm

⁽¹⁾Through car

⁽²⁾Beyond EN81-20/50, EN81-21

Traction RC.

Ideal for Low / Medium rise buildings, Private Villas & Properties, Limited Shaft requirements and Modernization Market.

Features:

- ▶ Wide range of Loading Capacity
- ▶ High speed solutions up to 2.5m/s
- ▶ Machine Room (M/R)
or Machine Room Less solutions (MRL)
- ▶ New Motor Base with several adjustment positions
- ▶ New arrangement of diverting pulleys / less ropes' wear
- ▶ Rear counterweight / less No of supporting brackets
- ▶ High strength of Car sling / Wide range of cabin finishes (Glass panoramic included)
- ▶ Conformity with EN81-20/50, EN81-21
- ▶ Low operational cost
- ▶ Easy installation & maintenance
- ▶ Automatic emergency operation in case of power failure as a standard

Use:



Passenger Lifts.



Panoramic Lifts.



Hospital Lifts.



High Rise Buildings.



Hotels.



Shopping Malls.



Residential.



Traction MR

Traction MRL

Traction RC MRL

Lift Type	Traction MRL RC 1.0m/s							
Max Capacity	300 kg	400 kg	630 kg	630 kg	800 kg	1000 kg	1000 kg	1425 kg
Min PIT EN81-20	1000mm	1000mm	1000mm	1000mm	1000mm	1000mm	1000mm	1050mm
Min PIT EN81-21	700*mm	700*mm	700*mm	700*mm	750*mm	750*mm	750*mm	800*mm
Min PIT ⁽²⁾	700*mm	700*mm	700*mm	700*mm	750*mm	750*mm	750*mm	800*mm
Min. Headroom EN81-20	4100mm	4100mm	4100mm	4100mm	4200mm	4200mm	4200mm	4300mm
Min. Headroom EN81-21	3600mm	3600mm	3600mm	3600mm	3700mm	3700mm	3700mm	3800mm
Min. Headroom ⁽²⁾	3600mm	3600mm	3600mm	3600mm	3700mm	3700mm	3700mm	3800mm
Car guide Rails	T70x65x9	T70x65x9	T70x65x9	T70x65x9	T82x68x9	T89x62x16	T89x62x16	T114x89x16
CW guide Rails	T50x50x5	T50x50x5	T50x50x5	T50x50x5	T70x65x9	T70x65x9	T70x65x9	T70x65x9
Travel	30000**	30000**	30000**	30000**	30000**	30000**	30000**	30000**
Machine Pulley	Φ320	Φ320	Φ320	Φ320	Φ400	Φ400	Φ400	Φ480
Acting	1:1	1:1	1:1	1:1	2:1	2:1	2:1	2:1
Standard Shaft	1300x1600	1450x1700	1800x1700	1550x2000	1750x2000	2500x1700	1650x2800	2700x2000
Standard Cabin	900x1000	1050x1100	1400x1100	1100x1400	1350x1400	2100x1100	1100x2100	2300x1400
Standard Door	650 side opening	700 side opening	900 side opening	800 side opening	900 side opening	1200 side opening	900 side opening	1200 central opening
Standard Cabinet:	400X200X2230mm	400X200X2230mm	400X200X2230mm	400X200X2230mm	400X200X2230mm	400X200X2230mm	400X200X2230mm	400X200X2230mm

*For travel more than 30000mm, a compensation chain is added and the pit depth must be ≥ 1000mm.

**Max Travel without compensation chain 30000mm. Max Travel with compensation chain 100000mm.

***For Internal Car height 2100mm

⁽²⁾Beyond EN81-20/50, EN81-21

Lift Type	Traction MRL RC 1.6m/s							
Max Capacity	300 kg	400 kg	630 kg	630 kg	800 kg	1000 kg	1000 kg	1425 kg
Min PIT EN81-20	1250mm	1250mm	1250mm	1250mm	1300mm	1300mm	1300mm	1350mm
Min PIT EN81-21	1050*mm	1050*mm	1050*mm	1050*mm	1100*mm	1100*mm	1100*mm	1150*mm
Min PIT ⁽²⁾	1050*mm	1050*mm	1050*mm	1050*mm	1100*mm	1100*mm	1100*mm	1150*mm
Min. Headroom EN81-20	4300mm	4300mm	4300mm	4300mm	4400mm	4400mm	4400mm	4500mm
Min. Headroom EN81-21	3750mm	3750mm	3750mm	3750mm	3850mm	3850mm	3850mm	3950mm
Min. Headroom ⁽²⁾	3750mm	3750mm	3750mm	3750mm	3850mm	3850mm	3850mm	3950mm
Car guide Rails	T70x65x9	T70x65x9	T70x65x9	T70x65x9	T82x68x9	T89x62x16	T89x62x16	T114x89x16
CW guide Rails	T50x50x5	T50x50x5	T50x50x5	T50x50x5	T70x65x9	T70x65x9	T70x65x9	T70x65x9
Travel	30000**	30000**	30000**	30000**	30000**	30000**	30000**	30000**
Machine Pulley	Φ320	Φ320	Φ320	Φ320	Φ400	Φ400	Φ400	Φ480
Acting	1:1	1:1	1:1	1:1	2:1	2:1	2:1	2:1
Standard Shaft	1300x1600	1450x1700	1800x1700	1550x2000	1750x2000	2500x1700	1650x2800	2700x2000
Standard Cabin	900x1000	1050x1100	1400x1100	1100x1400	1350x1400	2100x1100	1100x2100	2300x1400
Standard Door	650 side opening	700 side opening	900 side opening	800 side opening	900 side opening	1200 side opening	900 side opening	1200 central opening
Standard Cabinet:	400X200X2230mm	400X200X2230mm	400X200X2230mm	400X200X2230mm	400X200X2230mm	400X200X2230mm	400X200X2230mm	400X200X2230mm

*For travel more than 30000mm, a compensation chain is added and the pit depth must be ≥ 1200mm.

**Max Travel without compensation chain 30000mm. Max Travel with compensation chain 100000mm.

***For Internal Car height 2100mm

⁽²⁾Beyond EN81-20/50, EN81-21

Traction RC MRL

Lift Type	Traction MRL RC 2.0m/s							
Max Capacity	300 kg	400 kg	630 kg	630 kg	800 kg	1000 kg	1000 kg	1425 kg
Min PIT EN81-20	1350mm	1350mm	1350mm	1350mm	1400mm	1400mm	1400mm	1450mm
Min PIT EN81-21	1350mm	1350mm	1350mm	1350mm	1400mm	1400mm	1400mm	1450mm
Min PIT ⁽²⁾	1350mm	1350mm	1350mm	1350mm	1400mm	1400mm	1400mm	1450mm
Min. Headroom EN81-20	4400mm	4400mm	4400mm	4400mm	4500mm	4500mm	4500mm	4600mm
Min. Headroom EN81-21	3800mm	3800mm	3800mm	3800mm	3900mm	3900mm	3900mm	4000mm
Min. Headroom ⁽²⁾	3800mm	3800mm	3800mm	3800mm	3900mm	3900mm	3900mm	4000mm
Car guide Rails	T70x65x9	T70x65x9	T70x65x9	T70x65x9	T82x68x9	T89x62x16	T89x62x16	T114x89x16
CW guide Rails	T50x50x5	T50x50x5	T50x50x5	T50x50x5	T70x65x9	T70x65x9	T70x65x9	T70x65x9
Travel	30000**	30000**	30000**	30000**	30000**	30000**	30000**	30000**
Machine Pulley	Φ320	Φ320	Φ320	Φ320	Φ400	Φ400	Φ400	Φ480
Acting	1:1	1:1	1:1	1:1	2:1	2:1	2:1	2:1
Standard Shaft	1300x1600	1450x1700	1800x1700	1550x2000	1750x2000	2500x1700	1650x2800	2700x2000
Standard Cabin	900x1000	1050x1100	1400x1100	1100x1400	1350x1400	2100x1100	1100x2100	2300x1400
Standard Door	650 side opening	700 side opening	900 side opening	800 side opening	900 side opening	1200 side opening	900 side opening	1200 central opening
Standard Cabinet:	400X200X2230mm	400X200X2230mm	400X200X2230mm	400X200X2230mm	400X200X2230mm	400X200X2230mm	400X200X2230mm	400X200X2230mm

*For travel more than 30000mm, a compensation chain is added and the pit depth must be ≥ 1000mm.

**Max Travel without compensation chain 30000mm. Max Travel with compensation chain 100000mm.

***For Internal Car height 2100mm

⁽²⁾Beyond EN81-20/50, EN81-21

Lift Type	Traction MRL RC 2.5m/s							
Max Capacity	300 kg	400 kg	630 kg	630 kg	800 kg	1000 kg	1000 kg	1425 kg
Min PIT EN81-20	1750mm	1750mm	1750mm	1750mm	1800mm	1800mm	1800mm	1850mm
Min PIT EN81-21	1750mm	1750mm	1750mm	1750mm	1800mm	1800mm	1800mm	1850mm
Min PIT ⁽²⁾	1750mm	1750mm	1750mm	1750mm	1800mm	1800mm	1800mm	1850mm
Min. Headroom EN81-20	4700mm	4700mm	4700mm	4700mm	4800mm	4800mm	4800mm	4900mm
Min. Headroom EN81-21	4000mm	4000mm	4000mm	4000mm	4100mm	4100mm	4100mm	4200mm
Min. Headroom ⁽²⁾	4000mm	4000mm	4000mm	4000mm	4100mm	4100mm	4100mm	4200mm
Car guide Rails	T70x65x9	T70x65x9	T70x65x9	T70x65x9	T82x68x9	T89x62x16	T89x62x16	T114x89x16
CW guide Rails	T50x50x5	T50x50x5	T50x50x5	T50x50x5	T70x65x9	T70x65x9	T70x65x9	T70x65x9
Travel	30000**	30000**	30000**	30000**	30000**	30000**	30000**	30000**
Machine Pulley	Φ320	Φ320	Φ320	Φ320	Φ400	Φ400	Φ400	Φ480
Acting	1:1	1:1	1:1	1:1	2:1	2:1	2:1	2:1
Standard Shaft	1300x1600	1450x1700	1800x1700	1550x2000	1750x2000	2500x1700	1650x2800	2700x2000
Standard Cabin	900x1000	1050x1100	1400x1100	1100x1400	1350x1400	2100x1100	1100x2100	2300x1400
Standard Door	650 side opening	700 side opening	900 side opening	800 side opening	900 side opening	1200 side opening	900 side opening	1200 central opening
Standard Cabinet:	400X200X2230mm	400X200X2230mm	400X200X2230mm	400X200X2230mm	400X200X2230mm	400X200X2230mm	400X200X2230mm	400X200X2230mm

Traction RC MR

Lift Type	Traction MR RC 1.0m/s							
Max Capacity	300 kg	400 kg	630 kg	630 kg	800 kg	1000 kg	1000 kg	1425 kg
Min PIT EN81-20	1000mm	1000mm	1000mm	1000mm	1000mm	1000mm	1000mm	1050mm
Min PIT EN81-21	700*mm	700*mm	700*mm	700*mm	750*mm	750*mm	750*mm	800*mm
Min PIT ⁽²⁾	700*mm	700*mm	700*mm	700*mm	750*mm	750*mm	750*mm	800*mm
Min. Headroom EN81-20	3350mm	3350mm	3350mm	3350mm	3350mm	3350mm	3350mm	3350mm
Min. Headroom EN81-21	2850mm	2850mm	2850mm	2850mm	2850mm	2850mm	2850mm	2850mm
Min. Headroom ⁽²⁾	2850mm	2850mm	2850mm	2850mm	2850mm	2850mm	2850mm	2850mm
Car guide Rails	T70x65x9	T70x65x9	T70x65x9	T70x65x9	T70x65x9	T82x68x9	T82x68x9	T89x62x16
CW guide Rails	T50x50x5	T50x50x5	T50x50x5	T50x50x5	T50x50x5	T70x65x9	T70x65x9	T70x65x9
Travel	30000**	30000**	30000**	30000**	30000**	30000**	30000**	30000**
Machine Pulley	Φ320	Φ320	Φ320	Φ320	Φ400	Φ400	Φ400	Φ480
Acting	1:1	1:1	1:1	1:1	2:1	2:1	2:1	2:1
Standard Shaft	1300x1600	1450x1700	1800x1700	1550x2000	1750x2000	2500x1700	1650x2800	2700x2000
Standard Cabin	900x1000	1050x1100	1400x1100	1100x1400	1350x1400	2100x1100	1100x2100	2300x1400
Standard Door	650 side opening	700 side opening	900 side opening	800 side opening	900 side opening	1200 side opening	900 side opening	1200 side opening
Standard Cabinet:	400X200X2230mm	400X200X2230mm	400X200X2230mm	400X200X2230mm	400X200X2230mm	400X200X2230mm	400X200X2230mm	400X200X2230mm

*For travel more than 30000mm, a compensation chain is added and the pit depth must be ≥ 1000mm.

**Max Travel without compensation chain 30000mm. Max Travel with compensation chain 100000mm.

***For Internal Car height 2100mm

⁽²⁾Beyond EN81-20/50, EN81-21

Lift Type	Traction MR RC 1.6m/s							
Max Capacity	300 kg	400 kg	630 kg	630 kg	800 kg	1000 kg	1000 kg	1425 kg
Min PIT EN81-20	1250mm	1250mm	1250mm	1250mm	1300mm	1300mm	1300mm	1350mm
Min PIT EN81-21	1050*mm	1050*mm	1050*mm	1050*mm	1100*mm	1100*mm	1100*mm	1150*mm
Min PIT ⁽²⁾	1050*mm	1050*mm	1050*mm	1050*mm	1100*mm	1100*mm	1100*mm	1150*mm
Min. Headroom EN81-20	3550mm	3550mm	3550mm	3550mm	3550mm	3550mm	3550mm	3550mm
Min. Headroom EN81-21	3000mm	3000mm	3000mm	3000mm	3000mm	3000mm	3000mm	3000mm
Min. Headroom ⁽²⁾	3000mm	3000mm	3000mm	3000mm	3000mm	3000mm	3000mm	3000mm
Car guide Rails	T70x65x9	T70x65x9	T70x65x9	T70x65x9	T70x65x9	T82x68x9	T82x68x9	T89x62x16
CW guide Rails	T50x50x5	T50x50x5	T50x50x5	T50x50x5	T50x50x5	T70x65x9	T70x65x9	T70x65x9
Travel	30000**	30000**	30000**	30000**	30000**	30000**	30000**	30000**
Machine Pulley	Φ320	Φ320	Φ320	Φ320	Φ400	Φ400	Φ400	Φ480
Acting	1:1	1:1	1:1	1:1	2:1	2:1	2:1	2:1
Standard Shaft	1300x1600	1450x1700	1800x1700	1550x2000	1750x2000	2500x1700	1650x2800	2700x2000
Standard Cabin	900x1000	1050x1100	1400x1100	1100x1400	1350x1400	2100x1100	1100x2100	2300x1400
Standard Door	650 side opening	700 side opening	900 side opening	800 side opening	900 side opening	1200 side opening	900 side opening	1200 side opening
Standard Cabinet:	400X200X2230mm	400X200X2230mm	400X200X2230mm	400X200X2230mm	400X200X2230mm	400X200X2230mm	400X200X2230mm	400X200X2230mm

*For travel more than 30000mm, a compensation chain is added and the pit depth must be ≥ 1000mm.

**Max Travel without compensation chain 30000mm. Max Travel with compensation chain 100000mm.

***For Internal Car height 2100mm

⁽²⁾Beyond EN81-20/50, EN81-21

Traction RC MR

Lift Type	Traction MR RC 2.0m/s							
Max Capacity	300 kg	400 kg	630 kg	630 kg	800 kg	1000 kg	1000 kg	1425 kg
Min PIT EN81-20	1350mm	1350mm	1350mm	1350mm	1400mm	1400mm	1400mm	1450mm
Min PIT EN81-21	1350mm	1350mm	1350mm	1350mm	1400mm	1400mm	1400mm	1450mm
Min PIT ⁽²⁾	1350mm	1350mm	1350mm	1350mm	1400mm	1400mm	1400mm	1450mm
Min. Headroom EN81-20	3650mm	3650mm	3650mm	3650mm	3650mm	3650mm	3650mm	3650mm
Min. Headroom EN81-21	3050mm	3050mm	3050mm	3050mm	3050mm	3050mm	3050mm	3050mm
Min. Headroom ⁽²⁾	3050mm	3050mm	3050mm	3050mm	3050mm	3050mm	3050mm	3050mm
Car guide Rails	T70x65x9	T70x65x9	T70x65x9	T70x65x9	T70x65x9	T82x68x9	T82x68x9	T89x62x16
CW guide Rails	T50x50x5	T50x50x5	T50x50x5	T50x50x5	T50x50x5	T70x65x9	T70x65x9	T70x65x9
Travel	30000**	30000**	30000**	30000**	30000**	30000**	30000**	30000**
Machine Pulley	Φ320	Φ320	Φ320	Φ320	Φ400	Φ400	Φ400	Φ480
Acting	1:1	1:1	1:1	1:1	2:1	2:1	2:1	2:1
Standard Shaft	1300x1600	1450x1700	1800x1700	1550x2000	1750x2000	2500x1700	1650x2800	2700x2000
Standard Cabin	900x1000	1050x1100	1400x1100	1100x1400	1350x1400	2100x1100	1100x2100	2300x1400
Standard Door	650 side opening	700 side opening	900 side opening	800 side opening	900 side opening	1200 side opening	900 side opening	1200 central opening
Standard Cabinet:	400X200X2230mm	400X200X2230mm	400X200X2230mm	400X200X2230mm	400X200X2230mm	400X200X2230mm	400X200X2230mm	400X200X2230mm

*For travel more than 30000mm, a compensation chain is added and the pit depth must be ≥ 1000mm.

**Max Travel without compensation chain 30000mm. Max Travel with compensation chain 100000mm.

***For Internal Car height 2100mm

⁽²⁾Beyond EN81-20/50, EN81-21

Lift Type	Traction MR RC 2.5m/s							
Max Capacity	300 kg	400 kg	630 kg	630 kg	800 kg	1000 kg	1000 kg	1425 kg
Min PIT EN81-20	1750mm	1750mm	1750mm	1750mm	1800mm	1800mm	1800mm	1850mm
Min PIT EN81-21	1750mm	1750mm	1750mm	1750mm	1800mm	1800mm	1800mm	1850mm
Min PIT Beyond ⁽²⁾	1750mm	1750mm	1750mm	1750mm	1800mm	1800mm	1800mm	1850mm
Min. Headroom EN81-20	3950mm	3950mm	3950mm	3950mm	3950mm	3950mm	3950mm	3950mm
Min. Headroom EN81-21	3250mm	3250mm	3250mm	3250mm	3250mm	3250mm	3250mm	3250mm
Min. Headroom ⁽²⁾	3250mm	3250mm	3250mm	3250mm	3250mm	3250mm	3250mm	3250mm
Car guide Rails	T70x65x9	T70x65x9	T70x65x9	T70x65x9	T70x65x9	T82x68x9	T82x68x9	T89x62x16
CW guide Rails	T50x50x5	T50x50x5	T50x50x5	T50x50x5	T50x50x5	T70x65x9	T70x65x9	T70x65x9
Travel	30000**	30000**	30000**	30000**	30000**	30000**	30000**	30000**
Machine Pulley	Φ320	Φ320	Φ320	Φ320	Φ400	Φ400	Φ400	Φ480
Acting	1:1	1:1	1:1	1:1	2:1	2:1	2:1	2:1
Standard Shaft	1300x1600	1450x1700	1800x1700	1550x2000	1750x2000	2500x1700	1650x2800	2700x2000
Standard Cabin	900x1000	1050x1100	1400x1100	1100x1400	1350x1400	2100x1100	1100x2100	2300x1400
Standard Door	650 side opening	700 side opening	900 side opening	800 side opening	900 side opening	1200 side opening	900 side opening	1200 central opening
Standard Cabinet:	400X200X2230mm	400X200X2230mm	400X200X2230mm	400X200X2230mm	400X200X2230mm	400X200X2230mm	400X200X2230mm	400X200X2230mm

*For travel more than 30000mm, a compensation chain is added and the pit depth must be ≥ 1000mm.

**Max Travel without compensation chain 30000mm. Max Travel with compensation chain 100000mm.

***For Internal Car height 2100mm

⁽²⁾Beyond EN81-20/50, EN81-21



Focus.

Ideal for Low / Medium rise buildings, Private Villas & Properties,
Limited Shaft requirements and Modernization Market.

Features:

- ▶ Indoor / Outdoor usage
- ▶ Concrete shaft or Aluminum / Steel structure
- ▶ Fully Automatic Doors / Semiautomatic landing door and bus type car door available upon request
- ▶ Automatic calls
- ▶ Single phase power supply (up to 1.00 m/s , up to 630Kg)
- ▶ Three phase power supply
- ▶ Single entrance LPH
- ▶ Single entrance / Adjacent entrance / Through car layout arrangements LH- LW
- ▶ Low pit and headroom appliance
- ▶ Ease of installation (Guides at one side)
- ▶ Ease of maintenance
- ▶ Automatic emergency operation in case of power failure as a standard
- ▶ Conformity with EN81-20/50, EN81-21
- ▶ DIRECTIVE 2014/33/EU



Use:



Passenger Lifts.



Panoramic Lifts.



Hospital Lifts.



Home Lifts.



High Rise Buildings.



Hotels.



Shopping Malls.



Residential Buildings.

Please note:

- ▶ Technical specifications above apply to standard range of cabins and doors.
- ▶ Dimensions are indicative for specific shaft range.
- ▶ Shaft and cabin dimensions above are "clear" dimensions .
- ▶ For more info regarding technical specifications and finishes, please contact our Sales Representatives.

Technical Specifications

Focus LW



Specifications				
Max Capacity	300Kg	450Kg	630Kg	1000Kg
Max Speed	1.00 m/s	1.00 m/s	1.00 m/s	1.00 m/s
Min. PIT / EN81-20	1100mm	1100mm	1100mm	1150mm
Min. PIT / EN81-21	600mm	600mm	650mm	700mm
Min. Headroom EN81-20	3500mm	3500mm	3500mm	3600mm
Min. Headroom EN81-21	3400mm*	3400mm	3400mm	3500mm
Car guide Rails	T70x65x9	T70x65x9	T82.5x68x9	T89x62x16
CW guide Rails	T50x50x5	T50x50x5	T50x50x5	T50x50x5
Max Travel	30000mm	30000mm	30000mm	30000mm
Standard Shaft	1250x1350	1350x1600	1450x1750	1800x1950 1500x2450
Standard Cabin	900x1000	1000x1250	1100x1400	1400x1600 1100x2100
Standard Automatic Door	700mm 2PT	700mm 2PT	800mm 2PT	900mm 2PT 800mm 2PT
Standard Cabinet:	400X200X2230mm	400X200X2230mm	400X200X2230mm	400X200X2230mm

* 3400mm Not according to EN81-21

Focus LH



Specifications				
Max Capacity	300Kg	450Kg	630Kg	1000Kg
Max Speed	1.00 m/s	1.00 m/s	1.00 m/s	1.00 m/s
Min. PIT / EN81-20	1000mm	1000mm	1000mm	1000mm
Min. PIT / EN81-21	400mm	400mm	450mm	475mm
Min. Headroom EN81-20	3350mm	3350mm	3350mm	3350mm
Min. Headroom EN81-21	2850mm	2850mm	2850mm	2900mm
Car guide Rails	T70x65x9	T70x65x9	T82.5x68x9	T89x62x16
CW guide Rails	T50x50x5	T50x50x5	T50x50x5	T50x50x5
Max Travel	30000mm	30000mm	30000mm	30000mm
Standard Shaft	1400x1350	1500x1600	1600x1750	1950x1950 1650x2450
Standard Cabin	900x1000	1000x1250	1100x1400	1400x1600 1100x2100
Standard Door	700mm 2PT	800mm 2PT	900mm 2PT	1100mm 2PT 900mm 2PT
Standard Cabinet:	400X200X2230mm	400X200X2230mm	400X200X2230mm	400X200X2230mm

Technical Specifications

Focus LPH



Specifications			
Max Capacity	300Kg	450Kg	630Kg
Max Speed	0.63 m/s	0.63 m/s	0.63 m/s
Min. PIT / EN81-20	1000mm	1000mm	1000mm
Min. PIT / EN81-21	170mm	170mm	170mm
Min. Headroom EN81-20	3350mm	3350mm	3350mm
Min. Headroom EN81-21	2850mm	2850mm	2850mm
Car guide Rails	T70x65x9	T82.5x68x9	T89x62x16
CW guide Rails	T50x50x5	T50x50x5	T50x50x5
Max Travel	30000mm	30000mm	30000mm
Standard Shaft	1400x1350	1500x1600	1600x1800
Standard Cabin	900x1000	1000x1250	1100x1400
Standard Door	700mm 2PT	800mm 2PT	900mm 2PT
Standard Cabinet:	400X200X2230mm	400X200X2230mm	400X200X2230mm



ELLI

EN81-41:2010.

Ideal for Low / Medium rise buildings, private villas & properties,
Limited shaft requirements and Modernization Market.

Features:

- ▶ Indoor / Outdoor usage
- ▶ Concrete shaft or Aluminum / Steel structure
- ▶ Swing landing door, without car door
- ▶ Hold-to-run by car operation panel & automatic calls by landing operation panel
- ▶ Single phase power supply
- ▶ Three phase power supply
- ▶ Single entrance / Through car layout arrangements -LPH
- ▶ Single entrance / Adjacent entrance / through car layout arrangements - LH
- ▶ Low pit and headroom appliance
- ▶ Ease of installation (Guides at one side)
- ▶ Ease of maintenance
- ▶ Automatic emergency operation in case of power failure as a standard
- ▶ Conformity with EN81-41



Use:



Passenger Lifts.



Panoramic Lifts.



Hospital Lifts.



Home Lifts.



High Rise Buildings.



Hotels.



Shopping Malls.



Residential Buildings.

Please note:

- ▶ Technical specifications above apply to standard range of cabins and doors.
- ▶ Dimensions are indicative for specific shaft range.
- ▶ Shaft and cabin dimensions above are "clear" dimensions .
- ▶ For more info regarding technical specifications and finishes, please contact our Sales Representatives.

Technical Specifications

ELLI LPH



Specifications			
Max Capacity (Kg)	250	320	400
Max Speed (m/s)	0.15	0.15	0.15
Min. PIT / EN81-41:2010 (mm)	130	130	130
Min. Headroom EN81-41:2010 (mm)	*2660	*2660	*2660
Car Guide Rails (mm)	T70x65x9	T82.5x68x9	T89x62x16
Max Travel (mm)	12000	12000	12000
Standard Shaft (mm)	1200x1400	1270x1550	1500x1550
Standard Cabin (mm)	800x1250	900x1400	1100x1400
Standard Door (mm)	700	800	900

Internal cabin height 2100mm
 Plastic cabin floor
 Hinged landing door
 *Without cabin doors

ELLI LH



Specifications			
Max Capacity (kg)	250	320	400
Max Speed (m/s)	0.15	0.15	0.15
Min. PIT / EN81-41:2010 (mm)	300	300	300
Min. Headroom EN81-41:2010 (mm)	*2500	*2500	*2500
Car Guide Rails (mm)	T70x65x9	T82.5x68x9	T89x62x16
Max Travel (mm)	12000	12000	12000
Standard Shaft (mm)	1200x1400	1270x1550	1500x1550
Standard Cabin (mm)	800x1250	900x1400	1100x1400
Standard Door (mm)	700	800	900

Internal cabin height: 2100mm
 Plastic cabin floor
 Hinged landing door
 * Without cabin doors

ELLI

2006/42.

Where the need of automatic calls arise, ELLI 2006/42 is the ideal solution for Low / Medium rise buildings, private villas & properties. Fully automatic doors enhance the ease of use and aesthetics.

Features:

- ▶ Indoor / Outdoor usage
- ▶ Concrete shaft or Aluminum / Steel structure
- ▶ Fully Automatic Doors / Semiautomatic Landing Door and Bus type car door available upon request
- ▶ Automatic calls
- ▶ Single phase power supply
- ▶ Three phase power supply
- ▶ Single entrance - LPH
- ▶ Single entrance / Adjacent entrance / Through car layout arrangements - LH
- ▶ Low pit and headroom appliance
- ▶ Ease of installation (Guides at one side)
- ▶ Ease of maintenance
- ▶ Automatic emergency operation in case of power failure as a standard
- ▶ Conformity with part of standards EN81-20/21/41/50
- ▶ Directive 2006/42/EC

Use:



Passenger Lifts.



Panoramic Lifts.



Hospital Lifts.



Home lifts.



High Rise Buildings.



Hotels.



Shopping Malls.



Residential lifts.



Please note:

- ▶ Technical specifications above apply to standard range of cabins and doors.
- ▶ Dimensions are indicative for specific shaft range.
- ▶ Shaft and cabin dimensions above are "clear" dimensions .
- ▶ For more info regarding technical specifications and finishes, please contact our Sales Representatives.

Technical Specifications

ELLI LPH



Specifications			
Max Capacity (Kg)	250	320	400
Max Speed (m/s)	0.15	0.15	0.15
Min. PIT / EN81-41:2010 (mm)	170	170	170
Min. Headroom EN81-41:2010 (mm)	2700	2700	2700
Car Guide Rails (mm)	T70x65x9	T82.5x68x9	T89x62x16
Max Travel (mm)	12000	12000	12000
Standard Shaft (mm)	1300x1600	1400x1750	1600x1750
Standard Cabin (mm)	800x1250	900x1400	1100x1400
Standard Door (mm)	700	700	900

Automatic side sliding doors / Bus folding doors
 Internal cabin height 2100
 Plastic cabin floor
 Single entrance

ELLI LH



Specifications			
Max Capacity (kg)	250	320	400
Max Speed (m/s)	0.15	0.15	0.15
Min. PIT / EN81-41:2010 (mm)	300	300	300
Min. Headroom EN81-41:2010 (mm)	2600*(2500**)	2600*(2500**)	2600*(2500**)
Car Guide Rails (mm)	T70x65x9	T82.5x68x9	T89x62x16
Max Travel (mm)	12000	12000	12000
Standard Shaft (mm)	1300x1600	1400x1750	1600x1750
Standard Cabin (mm)	800x1250	900x1400	1100x1400
Standard Door (mm)	700	700	900

Internal cabin height 2100mm
 Plastic cabin floor
 *Automatic side sliding doors/**Bus folding doors

ELLI

EN 81-20.

Where the need for higher speeds arise, ELLI EN81-20 is the ideal solution for Low / Medium rise buildings, Private Villas & Properties.

Features:

- ▶ Indoor / Outdoor usage
- ▶ Concrete shaft or Aluminum / Steel structure
- ▶ Fully Automatic Doors / Semiautomatic landing door and Bus type car door available upon request
- ▶ Automatic calls
- ▶ Three phase power supply
- ▶ Single entrance - LPH
- ▶ Single entrance / Adjacent entrance / Through car layout arrangements - HFS
- ▶ Low pit and headroom appliance
- ▶ Ease of installation (Guides at one side)
- ▶ Ease of maintenance
- ▶ Automatic emergency operation in case of power failure as a standard
- ▶ Conformity with EN81-20/50, EN81-21
- ▶ Directive 2014/33/EC

Use:



Passenger Lifts.



Panoramic Lifts.



Hospital Lifts.



Home Lifts.



High Rise Buildings.



Hotels.



Shopping Malls.



Residential Buildings.



Please note:

- ▶ Technical specifications above apply to standard range of cabins and doors.
- ▶ Dimensions are indicative for specific shaft range.
- ▶ Shaft and cabin dimensions above are "clear" dimensions.
- ▶ For more info regarding technical specifications and finishes, please contact our Sales Representatives.

Technical Specifications

ELLI LPH



Specifications			
Max Capacity (Kg)	300Kg	450Kg	630Kg
Max Speed (m/s)	0.63 m/s	0.63 m/s	0.63 m/s
Min. PIT / EN81-20 (mm)	170	170	170
Min. PIT EN81-21 (mm)	130	130	170
Min. Headroom EN81-20 (mm)	3350	3350	3350
Min. Headroom EN81-21 (mm)	2700	2700	2750
Car Guide Rails (mm)	T70x65x9	T82.5x68x9	T89x62x16
Max Travel (mm)	20000	20000	20000
Standard Shaft (mm)	1300x1350	1400x1600	1550x1800
Standard Cabin (mm)	900x1000	1000x1250	1100x1400
Standard Door (mm)	700 2PT	700 2PT	900 2PT

ELLI HFS



Specifications				
Max Capacity (Kg)	300	450	630	1000
Max Speed (mm)	0.63	0.63	0.63	0.63
Min. PIT EN81-20 (mm)	1000	1000	1000	1000
Min. PIT EN 81-21 (mm)	400	400	420	480
Min. Headroom EN81-20 (mm)	3350	3350	3350	3350
Min. Headroom EN81-21 (mm)	2600 (2500)*	2600 (2500)*	2600 (2500)*	2600 (2500)*
Car Guide Rails (mm)	T70x65x9	T82.5x68x9	T89x62x16	T89x62x16
Max Travel (mm)	20000	20000	20000	20000
Standard Shaft (mm)	1300x1350	1400x1600	1550x1800	1550x2500
Standard Cabin (mm)	900x1000	1000x1250	1100x1400	1100x2100
Standard Door (mm)	700 2PT	800 2PT	900 2PT	900 2PT

* Cabin door type BUS
Internal cabin height 2100
Plastic cabin floor

Elli HFS TMRL Passenger Lift.

Features:

- ▶ Speed up to 0.63m/sec
- ▶ Automatic emergency operation in case of power failure as a standard
- ▶ With machine room or without
- ▶ Conformity with EN81-20/50, EN81-21
- ▶ Compliance with Directive 2014/33/EU

Use:



Specifications HFS TMRL

	450kg	630kg	750kg	1000kg
Max. Capacity	450kg	630kg	750kg	1000kg
Min. PIT (EN81-20)	1200mm	1200mm	1200mm	1200mm
Min. Headroom (EN81-20)	3350mm	3350mm	3350mm	3350mm
Min. Headroom (EN81-21)	2600mm 2500mm*	2600mm 2500mm*	2850mm	2850mm
Travel	15000mm	15000mm	15000mm	15000mm
Standard Shaft	1500x1600	1600x1800	1700x1900	1800x2200
Standard Cabin	1000x1200	1100x1400	1200x1500	1300x1800
Standard Door	800mm 2PT	900mm 2PT	900mm 2PT	1000mm 2PT

* Cabin door type BUS



Doppler Hydraulic Power units MR/MRL/TMRL.

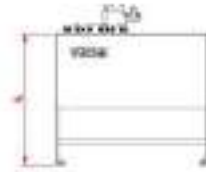

Specifications MR power units

Type	Fill Volume(l)	Useable oil volume (l)	A(mm)	B(mm)	C(mm)
D60	60	35	585	400	650
D108	108	78	740	400	760
D144	144	104	740	400	1000
D262	262	197	900	500	1000
D348	348	283	1100	500	1000
D488	488	398	1050	600	1260
D624	624	489	1130	750	1260
D836	836	682	1200	930	1260
D1200	1200	1000	1200	930	1550

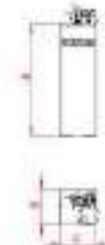

Specifications MRL Power Units / Control valve and power unit in the cabinet

Type	Fill Volume (l)	Useable Oil Volume (l)	A(mm)	B(mm)	C(mm)	D(mm)	F(mm)	E(mm)
MRL40	51	38	800	250	270	2140	360	360
MRL70	70	50	800	250	370	2140	460	360

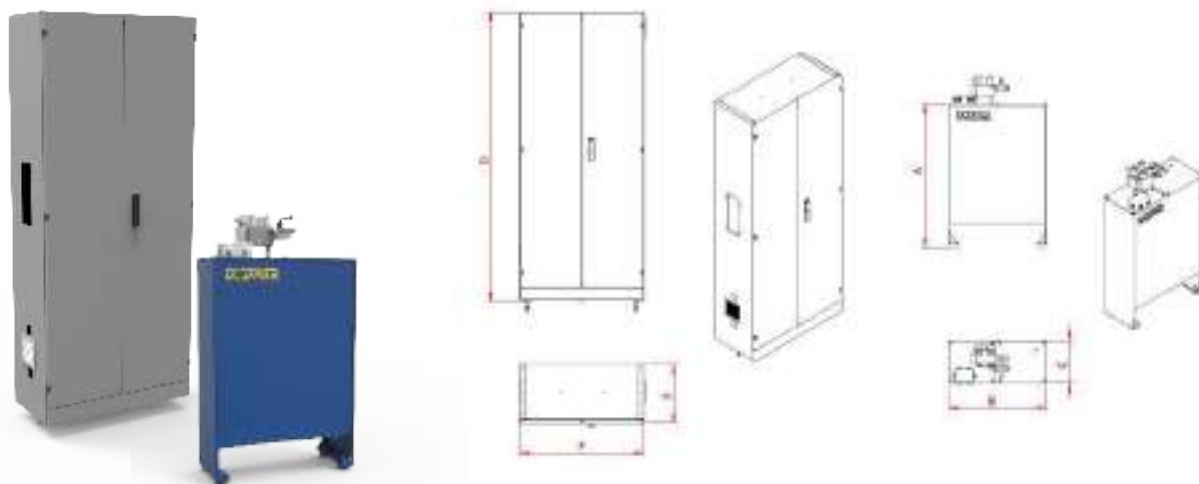

Specifications MRL Power Units / Central Opening Cabinet

Type	Fill Volume (l)	Useable Oil Volume (l)	A(mm)	B(mm)	C(mm)	D(mm)	F(mm)	E(mm)
MRL60	60	35	585	650	400	1600	850	500
MRL100	100	70	1000	700	300	2000	850	400
MRL300	300	240	1000	890	450	2000	1100	600



Specifications T-MRL Power Units / Control valve in the cabinet, power unit in the shaft

Type	Fill Volume (l)	Useable Volume (l)	A(mm)	B(mm)	C(mm)
TMRL207	207	126	730	400	1150
TMRL264	264	157	730	400	1400

Twin Jack Direct [1:1] Acting Hydraulic Lift.

Features:

- ▶ Lifting Capacity up to 20.000kg
- ▶ Speed up to 0,63m/sec
- ▶ Low noise & smooth operation
- ▶ Available with various cabin types
- ▶ Automatic emergency operation in case of power failure as a standard
- ▶ Machine room at any location in relation to the lift shaft
- ▶ Double COP in any case of through car arrangement
- ▶ Conformity with EN81-20/50, EN81-21
- ▶ Compliance with Directive 2014/33/EU



Use:



Specifications HAD EN 81-20/50, Table 6 (Single Entrance)

	2000kg	2500kg	3000kg	3500kg	4000kg	5000kg
Max. Capacity ⁽²⁾	2000kg	2500kg	3000kg	3500kg	4000kg	5000kg
Max. Speed	0,63m/s	0,63m/s	0,63m/s	0,63m/s	0,63m/s	0,63m/s
Min. Pit (81.20)	950mm	950mm	950mm	950mm	950mm	1350mm
Min. Headroom (81.20)	Depends on the Travel					
Min. Pit (81.21)	700mm	700mm	700mm	700mm	700mm	700mm
Min. Headroom (81.21)	Depends on the Travel					
Car guide rails	89x62x16mm	89x62x16mm	89x62x16mm	89x62x16mm	114x89x16mm	114x89x16mm
Standard Shaft	2600x2600mm	2800x2900mm	2900x3300mm	3000x3500mm	3200x3600mm	3900x3400mm
Standard Cabin	1800x2200mm	2000x2500mm	2000x2900mm	2100x3100mm	2300x3200mm	3000x3000mm
Standard Door	1600mm	1700mm	1800mm	1900mm	2000mm	2500mm

Specifications HAD EN 81-20/50, Table 6 (Double Entrance)

Max. Capacity ⁽²⁾	2000kg	2500kg	3000kg	3500kg	4000kg	5000kg
Max. Speed	0,63m/s	0,63m/s	0,63m/s	0,63m/s	0,63m/s	0,63m/s
Min. Pit (81.20)	950mm	950mm	950mm	1000mm	1000mm	1350mm
Min. Headroom (81.20)	Depends on the Travel					
Min. Pit (81.21)	700mm	700mm	700mm	700mm	700mm	800mm
Min. Headroom (81.21)	Depends on the Travel					
Car guide rails	89x62x16mm	89x62x16mm	89x62x16mm	89x62x16mm	114x89x16mm	114x89x16mm
Standard Shaft	2600x2800mm	2800x3100mm	2900x3500mm	3000x3700mm	3200x3800mm	3900x3600mm
Standard Cabin	1800x2200mm	2000x2500mm	2000x2900mm	2100x3100mm	2300x3200mm	3000x3000mm
Standard Door	1600mm	1700mm	1800mm	1900mm	2000mm	2500mm

Specifications HAD EN 81-20/50, Table 7 (Single Entrance) ⁽¹⁾

Max. Capacity ⁽²⁾	3600kg	3800kg	4000kg	4200kg	5000kg
Max. Speed	0,63m/s	0,63m/s	0,63m/s	0,63m/s	0,63m/s
Min. Pit (81.20)	1350mm	1350mm	1350mm	1350mm	1350mm
Min. Headroom (81.20)	Depends on the Travel				
Min. Pit (81.21)	800mm	800mm	800mm	800mm	800mm
Min. Headroom (81.21)	Depends on the Travel				
Car guide rails	127x89x16-3mm	127x89x16-3mm	127x89x16-3mm	127x89x16-3mm	127x89x16-3mm
Standard Shaft	3300x5900mm	3400x6000mm	3500x6100mm	3650x6200mm	4200x6500mm
Standard Cabin	2400x5400mm	2500x5500mm	2600x5600mm	2700x5700mm	3100x6000mm
Standard Door	2300mm	2400mm	2500mm	2600mm	3000mm

Specifications HAD EN 81-20/50, Table 7 (Double Entrance) ⁽¹⁾

Max. Capacity ⁽²⁾	3600kg	3800kg	4000kg	4200kg	5000kg
Max. Speed	0,63m/s	0,63m/s	0,63m/s	0,63m/s	0,63m/s
Min. Pit (81.20)	1350mm	1350mm	1350mm	1350mm	1350mm
Min. Headroom (81.20)	Depends on the Travel				
Min. Pit (81.21)	800mm	800mm	800mm	800mm	800mm
Min. Headroom (81.21)	Depends on the Travel				
Car guide rails	127x89x16-3mm	127x89x16-3mm	127x89x16-3mm	127x89x16-3mm	127x89x16-3mm
Standard Shaft	3300x6150mm	3400x6250mm	3500x6350mm	3650x6450mm	4200x6750mm
Standard Cabin	2400x5400mm	2500x5500mm	2600x5600mm	2700x5700mm	3100x6000mm
Standard Door	2300mm	2400mm	2500mm	2600mm	3000mm

⁽²⁾ According to EN 81-20 5.4.2.2 Goods passenger lifts
⁽²⁾ Clear weight (without forklift's weight included).

Twin Jack Indirect [1:2] Acting Hydraulic Lift.

Features:

- ▶ Lifting Capacity up to 11.000kg
- ▶ Speed up to 0,63 m/sec
- ▶ Low noise & smooth operation
- ▶ Available with various cabin types
- ▶ Automatic emergency operation in case of power failure as a standard
- ▶ Machine room at any location in relation to the lift shaft
- ▶ Double COP in any case of through car arrangement
- ▶ Conformity with EN81-20/50
- ▶ Compliance with Directive 2014/33/EU

Use:

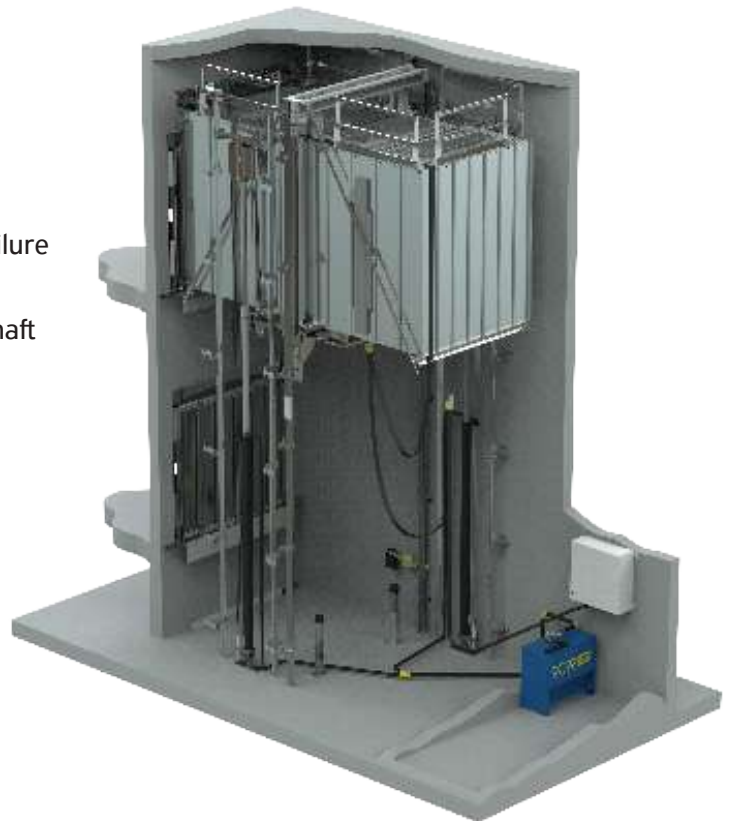

Specifications HADI EN 81-20/50, Table 6 (Single Entrance)

Max. Capacity ⁽²⁾	2000kg	2500kg	3000kg	3500kg	4000kg	5000kg
Max. Speed	0,63m/s	0,63m/s	0,63m/s	0,63m/s	0,63m/s	0,63m/s
Min. Pit (81.20)	950mm	950mm	950mm	950mm	950mm	13500mm
Min. Headroom (81.20)	3400mm	3400mm	3400mm	3400mm	3400mm	3400mm
Min. Pit (81.21)	800mm	800mm	800mm	800mm	800mm	1000mm
Min. Headroom (81.21)	2900mm	2900mm	2900mm	2900mm	2900mm	2900mm
Car guide rails	89x62x16mm	90x75x16mm	114x89x16mm	114x89x16mm	127x89x16-3mm	127x89x16-3mm
Max. Travel	25000mm	25000mm	25000mm	25000mm	25000mm	25000mm
Standard Shaft	2600x2600mm	2800x2900mm	2900x3300mm	3000x3500mm	3200x3600mm	3900x3400mm
Standard Cabin	1800x2200mm	2000x2500mm	2000x2900mm	2100x3100mm	2300x3200mm	3000x3000mm
Standard Door	1600mm	1700mm	1800mm	1900mm	2000mm	2500mm

Specifications HADI EN 81-20/50, Table 6 (Double Entrance) ⁽¹⁾

Max. Capacity ⁽²⁾	2000kg	2500kg	3000kg	3500kg	4000kg	5000kg
Max. Speed	0,63m/s	0,63m/s	0,63m/s	0,63m/s	0,63m/s	0,63m/s
Min. Pit (81.20)	950mm	950mm	950mm	950mm	950mm	1350mm
Min. Headroom (81.20)	3400mm	3400mm	3400mm	3400mm	3400mm	3400mm
Min. Pit (81.21)	800mm	800mm	800mm	800mm	800mm	1000mm
Min. Headroom (81.21)	2900mm	2900mm	2900mm	2900mm	2900mm	2900mm
Car guide rails	89x62x16mm	90x75x16mm	114x89x16mm	114x89x16mm	127x89x16-3mm	127x89x16-3mm
Max. Travel	25000mm	25000mm	25000mm	25000mm	25000mm	25000mm
Standard Shaft	2600x2800mm	2800x3100mm	2900x3500mm	3000x3700mm	3200x3800mm	3900x3600mm
Standard Cabin	1800x2200mm	2000x2500mm	2000x2900mm	2100x3100mm	2300x3200mm	3000x3000mm
Standard Door	1600mm	1700mm	1800mm	1900mm	2000mm	2500mm

Specifications HADI EN 81-20/50, Table 7 (Single Entrance) ⁽¹⁾

Max. Capacity ⁽²⁾	3600kg	3800kg	4000kg	4200kg	5000kg
Max. Speed	0,63m/s	0,63m/s	0,63m/s	0,63m/s	0,63m/s
Min. Pit (81.20)	1350mm	1350mm	1350mm	1350mm	1400mm
Min. Headroom (81.20)	3500mm	3800mm	4100mm	4400mm	4400mm
Min. Pit (81.21)	1000mm	1000mm	1000mm	1000mm	1050mm
Min. Headroom (81.21)	3000mm	3300mm	3600mm	3900mm	3900mm
Car guide rails	127x89x16-3mm	127x89x16-3mm	127x89x16-3mm	127x89x16-3mm	140x102x29mm
Max. Travel	25000mm	25000mm	25000mm	25000mm	21000mm
Standard Shaft	3300x5900mm	3400x6000mm	3500x6100mm	3650x6200mm	4200x6500mm
Standard Cabin	2400x5400mm	2500x5500mm	2600x5600mm	2700x5700mm	3100x6000mm
Standard Door	2300mm	2400mm	2500mm	2600mm	3000mm

Specifications HADI EN 81-20/50, Table 7 (Double Entrance) ^{(1),(2)}

Max. Capacity ⁽²⁾	3600kg	3800kg	4000kg	4200kg	5000kg
Max. Speed	0,63m/s	0,63m/s	0,63m/s	0,63m/s	0,63m/s
Min. Pit (81.20)	1350mm	1350mm	1350mm	1350mm	1400mm
Min. Headroom (81.20)	3400mm	3400mm	3700mm	3900mm	3900mm
Min. Pit (81.21)	1000mm	1000mm	1000mm	1000mm	1050mm
Min. Headroom (81.21)	2900mm	2900mm	3200mm	3400mm	3400mm
Car guide rails	127x89x16-3mm	127x89x16-3mm	127x89x16-3mm	127x89x16-3mm	140x102x29mm
Max. Travel	25000mm	25000mm	25000mm	25000mm	21000mm
Standard Shaft	3300x6150mm	3400x6250mm	3500x6350mm	3650x6450mm	4200x6750mm
Standard Cabin	2400x5400mm	2500x5500mm	2600x5600mm	2700x5700mm	3100x6000mm
Standard Door	2300mm	2400mm	2500mm	2600mm	3000mm

⁽²⁾ According to EN 81-20 5.4.2.2 Goods passenger lifts
⁽²⁾ Clear weight (without forklift's weight included).

⁽²⁾ Internal Cabin Height= 2100mm

Double ELLI Car Lift.

Features:

- ▶ Capacity range up to 3.000kg
- ▶ Speed up to 0.15 m/sec
- ▶ Travel up to 12m
- ▶ Person/Driver allowed
- ▶ Automatic call outside
- ▶ Constant pressure call inside
- ▶ Automatic emergency operation in case of power failure as a standard
- ▶ Safety gear
- ▶ Piston rupture valve
- ▶ Compliance with Machinery Directive 2006/42/EC and EN81-31

Use:



Car Lifts.



Cargo Lifts.



Hospital Lifts.



Hotels.



Shopping malls.



Residential.

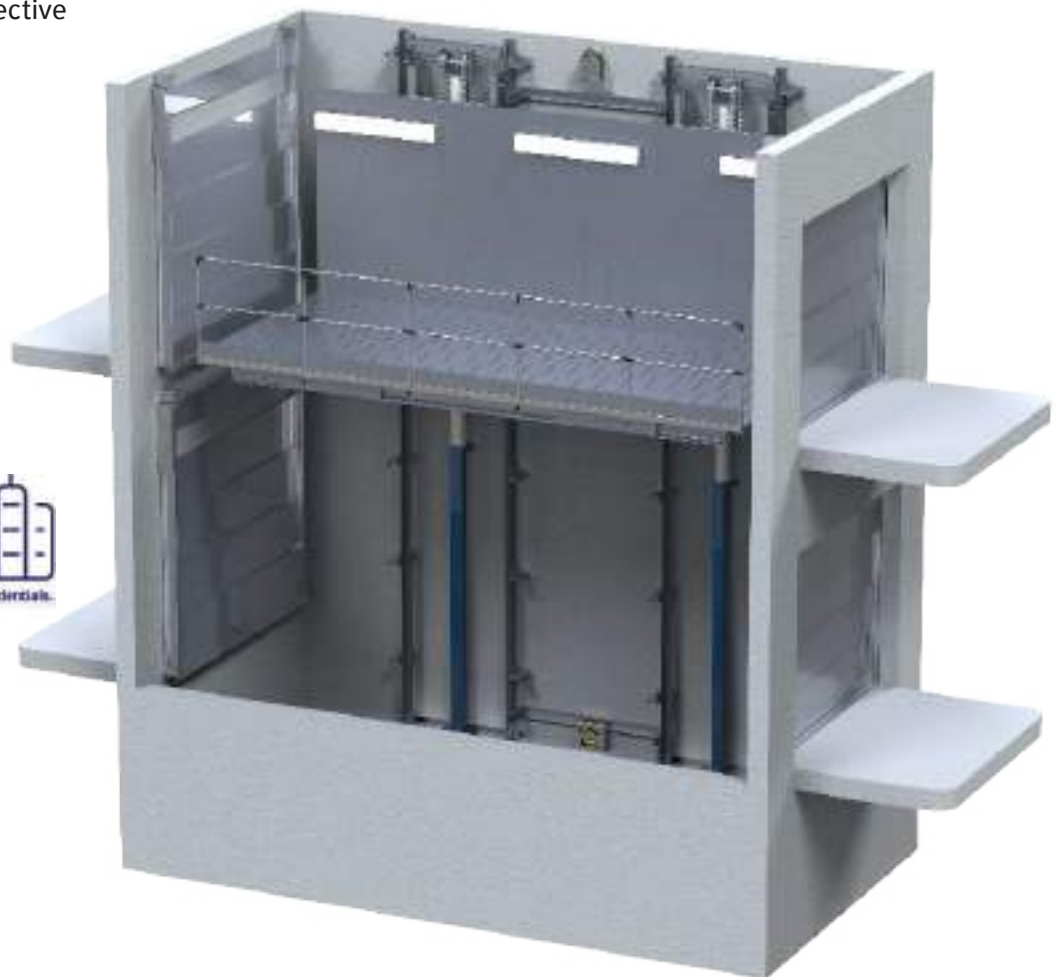

Double ELLI Car Lift.

Specifications:

ELLI Car lift EN81-31			
Rated Load (kg)	2.000 Kg	2.500 Kg	3.000 Kg
Acting	Hydraulic lifting mechanism 1:2		
Max Speed (m/s)	0.15		
Min. PIT (mm)	400mm		
Min. Headroom (mm)	2750mm		
Car guide rails	114x89x16	127x89x16-3	
Max. Travel (mm)	12000		
Min. Shaft (mm)	3050x4050	3050x5050	3050x6050
Max. Cabin (mm)	2500x4000	2500x5000	2500x6000
Standard Door (mm)	2500x2000	2500x2000	2500x2000
Piston (mm)	Ø100-Ø120		
Pumb (l/min)	75-100		
Motor (kW)	5.9-9.6		

ELLI Car lift 2006-42			
Rated Load (kg)	2.000 Kg	2.500 Kg	3.000 Kg
Acting	Hydraulic lifting mechanism 1:2		
Max Speed (m/s)	0.15		
Min. PIT (mm)	400		
Min. Headroom (mm)	2600*		
Car guide rails	114x89x16	127x89x16-3	
Max. Travel (mm)	12000		
Distance A (mm)	400		
Distance C (mm)	150		
Min. Shaft (mm)	3050x4050	3050x5050	3050x6050
Max. Cabin (mm)	2500x4000	2500x5000	2500x6000
Standard Door (mm)	2500x2000	2500x2000	2500x2000
Piston (mm)	Ø100-Ø120		
Pumb (l/min)	75-100		
Motor (kW)	5.9-9.6		

* with hinged landing door or Roll shutter. For ROYAL vertical door the minimum Headroom should be 2750mm.

Dumbwaiter.

Features:

- ▶ Compliance with Directive EN81-3
- ▶ Lifting capacity up to 300kg
- ▶ Speed up to 0.5 m/sec
- ▶ Travel up to 15000mm
- ▶ Available with bi-parting/swing doors

Use:



Dumbwaiters.



Hospital Lifts.



Hotels.



Shopping Malls.



Residential.



Specifications

Nominal Load:	100 Kg	250/300 Kg
Suspension:	1:1	1:1
Maximum Travel:	15.000 mm	20.000 mm
Suspended Load (P + Q)max	200 Kg	450 Kg
Minimum Headroom (Typical)	2550mm (2750mm with safety gear) Serving Height (800mm)+ Cabin Height (1000mm)+ Shaft components height (750mm without safety gear/950mm with safety gear DISG220)	2600mm (2800mm with safety gear) Serving Height (800mm)+ Cabin Height (1000mm)+ Shaft components height (800mm without safety gear/1000mm with safety gear DISG220)
Minimum Pit Depth + Serving Height:	Door Height / 2 + 200 mm*	Door Height / 2 + 200 mm*
Car Guides:	T50x50x5	T70x65x9
Counterweight Guides:	T50x50x5	T50x50x5
Car DBG:	450mm-800mm	600mm-900mm
Counterweight DBG:	Car DBG – 208mm	Car DBG – 320mm
Motor type:	WORMGEARED MOTOR	WORMGEARED MOTOR
Motor wattage:	0.75 kW	1.5 kW
VVVF		
Minimum operating temperature:	- 30° C	- 30° C
Controller's Minimum operating temperature:	-10° C	-10° C
Sheave:	Ø200 mm	Ø200 mm
Nominal Speed:	0,5 m/s (VVVF)	0,5 m/s (VVVF)
Wire Ropes:	2xØ6 mm	2xØ6 mm
Buffer:	ACLA Ø80x80mm	ACLA Ø80x80mm
Safety Gear	instantaneous	instantaneous







Modernization & Lift components.

Solutions EN81-20 & EN81-21.





A company's flexibility is shown not only with the integrated solutions of full lift systems, but also whether it can be supportive in individual cases, e.g. a renovation of a damage or old part.

Components of superior quality in a large variety (motors, ropes, pistons, power units, controllers, cabins, doors etc.), are covering with outmost safety and reliability every need.

For a greater convenience, DOPPLER is currently working on an online catalogue where you can find details on any component.

Modernization Kit.

Hydraulics

POWER UNIT	MOTOR	HYDRAULIC PUMP	CAR SLING	PISTON
High quality control valve block. Smooth operation with low noise levels. Standard automatic emergency operation.	Low noise, highly efficient, with integrated flywheel.	Extremely low noise level screw pump.	Stiff structure for safe operation made by DOPPLER. Safety gear mechanism absolutely reliable in activation. Easy & quick installation.	High quality seal without oil leakages by HYDRONIC, OMAR & COAM. Minimum maintenance required.
				

GUIDE RAILS	PULLEY	VALVE BLOCK	SHAFT COMPONENTS
Supplied by top quality manufacturers.	DOPPLER produces the two-point suspension pulley.	BLAIN & BUCHER with a wide range of adjustments.	ACLA buffers & European made ropes.
			

Motors

MOTORS		
Alternative choices between double-speed or VVVF, geared or gearless. Manufactured by DOPPLER, SASSI & MONTANARI. Low noise and vibration levels. Long life span.		
		

MOTOR BASE	SAFETY GEAR	SPEED GOVERNOR
Motor bases manufactured by DOPPLER.	Instantaneous Safety gears (DOPPLER) or Progressive (Dynatech, Cobiانchi)	Speed Governors from PFB.
		



Wireless monitoring

- ▶ Checking elevator status
- ▶ Changing Parameters application
- ▶ Calling Operation
- ▶ 3G Speed

“ Doppler is continuously moving,
TO THE NEW ERA.
President - CEO ”

Electricals.

INVERTER

The GEFRAN Inverters designed for new installations and upgrades, are the ideal system for a wide range of applications, including very low rise (homelifts) or very high rise (skyscrapers).



UPS

Modified Sine Wave Output ▶ RS232 and USB interface
DC Start ▶ Complete software monitoring system



LED Shaft lighting

LED technology applied to all shafts instead of high consumption typical lights.
▶ Shaft lights - LED strip ▶ Lights buttons & pit sockets ▶ Led strip mounting



Shaft Wiring

Improved wiring in order to facilitate the installation of wirings, reducing cost and work hours to minimum.

- ▶ Display & calls connections
- ▶ Headroom & pit connection box
- ▶ Floor door safety contacts
- ▶ Pit inspection controller connection extension



CONTROLLER

Suitable for Hydraulic and Traction lifts ▶ Up to 64 stops
Parallel, cabin serial, cabin & landings serial communication
Internal 3-phase and thermistor monitoring circuits ▶ Real-time clock & date
Internal Door Bridging controller for hydraulic applications
Two doors independent control ▶ Voice Announcer ▶ Emergency Rescue Operation
In conformity with EN81-70, EN81-72 (firefighter lifts standard), EN81-73
Special software for lift access security



DOPPLER electric Movable Stop Folding Buffer.

This device has been designed by DOPPLER in accordance with EN81-20 / EN81-21 ,to provide sufficient refuge spaces in the pit when a person enters in the pit.

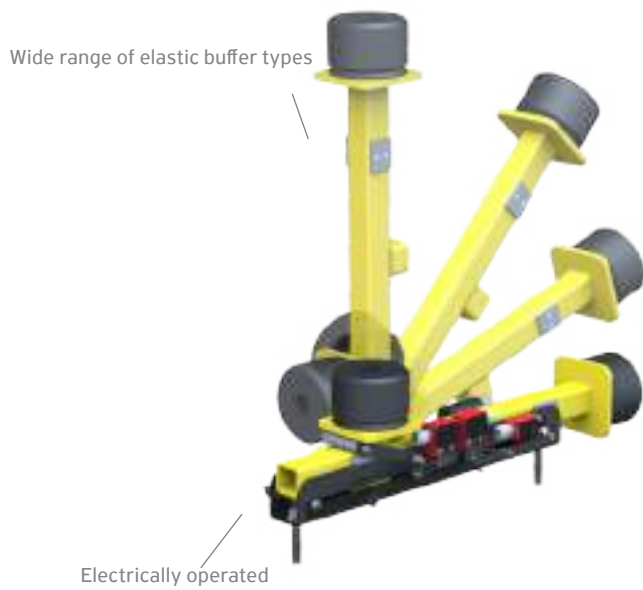

Ease of operation using constant pressure control box



Visible information about folding buffer state

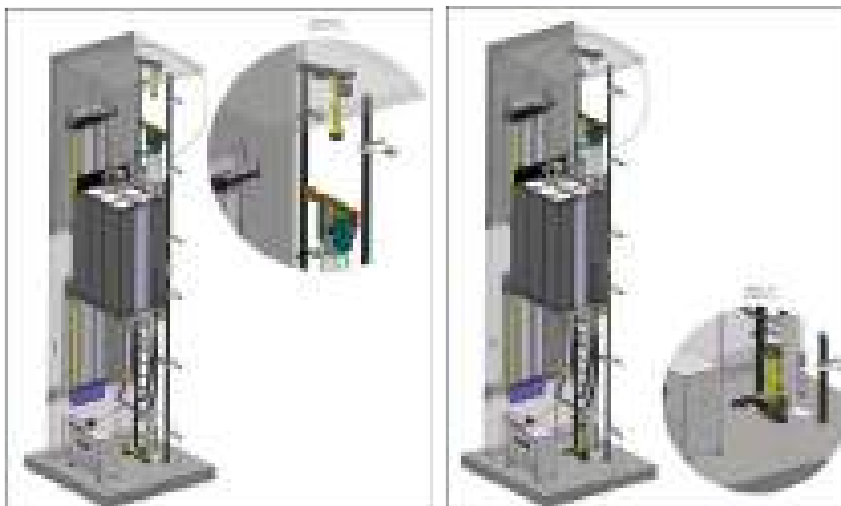

Folding Buffer Light & Heavy Duty		
Type	Max. Load Kg	Speed m/s
Heavy duty	3900 Kg	Up to 1m/s
Light Duty	2900 Kg	Up to 1m/s

DOPPLER electric Movable Stop Moving Buffer.

This device has been designed by Doppler S.A. to provide solutions for low pit and/or low headroom elevator wells and it is in accordance with EN81-21 (This European Standard specifies the safety rules related to new passenger and goods/passenger lifts permanently installed in existing buildings where in some circumstances due to limitations enforced by building constraints, some requirements of EN 81-20:2014 cannot be met)



Ease of operation using constant pressure control box



Visible information about folding buffer state

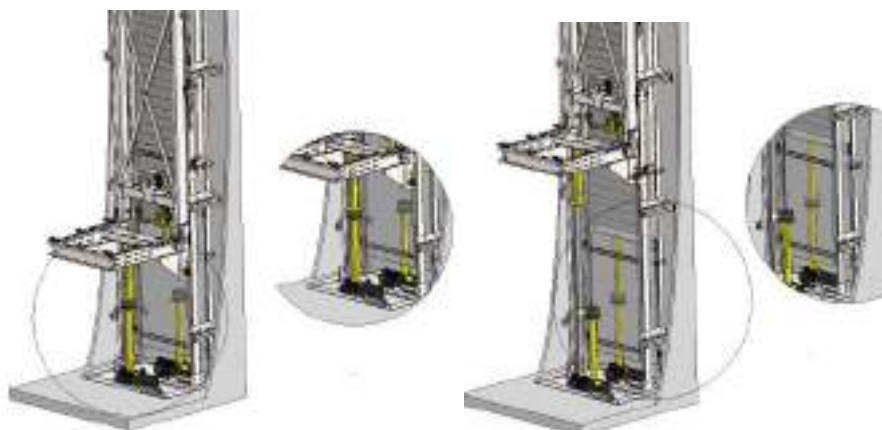

Folding Buffer Light & Heavy Duty		
Type	Max. Load Kg	Speed m/s
MB	2350 Kg	Up to 1 m/s
MB HR	3250 Kg	Up to 1.6 m/s

DOPPLER Car Aprons.

Typical, hinged and telescopic car aprons.

Car Aprons

- ▶ Equipped with electrical safety contact for supervision of car apron's state
- ▶ Unlocks with the use of one of the triangular locks
- ▶ Equipped with three triangular locks for left, right or centrally closing doors
- ▶ Car door width range 600mm-1500mm
- ▶ Easy installation on every car door sill
- ▶ Compliant with EN81-20 & EN81-21



Specifications

Type	Pit depth	Lift standards
Hinged	150mm - 400mm	EN 81-21
3-parts Telescopic	400mm - 510mm	EN 81-21
2-parts Telescopic	510mm - 870mm	EN 81-21
Typical	870mm - 950mm	EN 81-21
Typical	≥ 950mm	EN 81-20

DOPPLER Balustrades.

Typical and telescopic balustrades.

Balustrades (Typical & Telescopic)

- ▶ Compliant with EN81-20 & EN81-21
- ▶ Easy assembly & installation on the car roof
- ▶ Apply to very low headrooms
- ▶ Easy to use
- ▶ Fine aesthetics



Specifications

Type	Typical balustrades	Telescopic balustrades
Maximum Length	2850 mm	900 mm
Maximum Height	700 mm & 1100 mm	

DOPPLER Pit Ladder.

Pit Ladder (Steel & Aluminum)

- ▶ Compliant with EN81-20 Type 2b
- ▶ Retractable with electrical safety contact
- ▶ Easy installation
- ▶ Withstands loads up to 150 kg / EN131
- ▶ Light-weight design



Specifications

Type	Aluminum		
Ladder Length	2800 mm	3100 mm	3900 mm
Pit Depth	500 mm - 1550 mm	1550 mm - 1800 mm	1800 mm - 2650 mm

Specifications

Type	Steel		
Ladder Length	2650 mm	3300 mm	3800 mm
Pit Depth	500 mm - 1400 mm	1400 mm - 2000 mm	2000 mm - 2500 mm

DOPPLER Firefighting cabin roof and false ceiling.

Firefighting cabin roof & false ceiling

- ▶ Parts are designed in compliance with EN81-72.
- ▶ A telescopic ladder is located between false ceiling and car roof. Limited dimensions when in stored position / reaching up to 3.8m length when extended.
- ▶ Car fitted with trap doors on the ceiling and car roof, allowing the operation of self and external rescue procedures.

▶ False ceiling

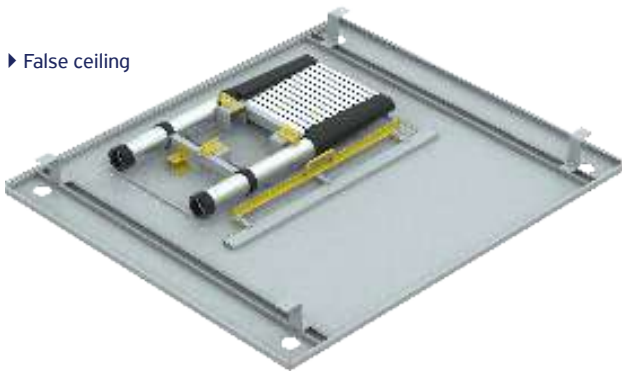

▶ Cabin roof

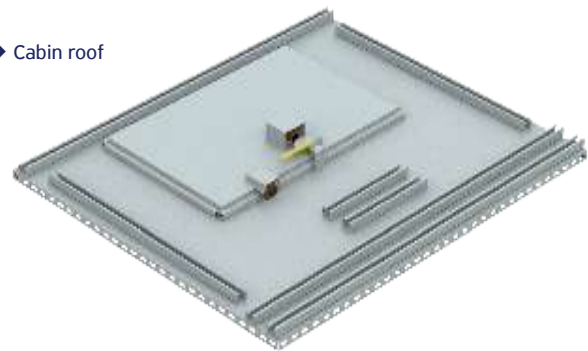

▶ Assembly

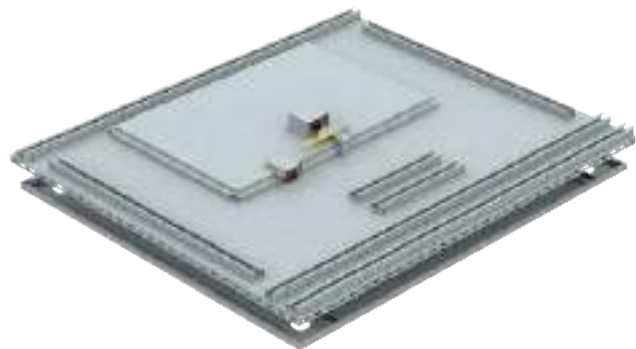
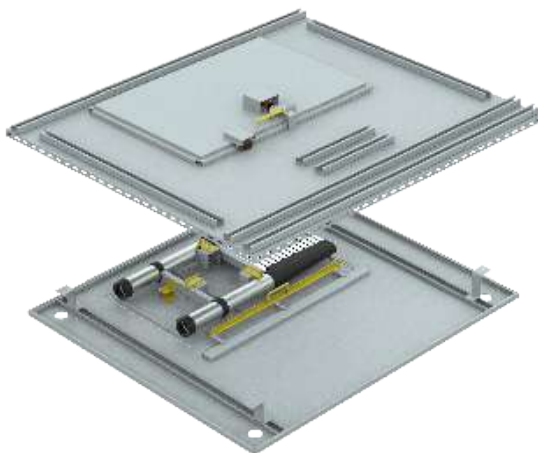





Escalators.

All You Need is a Single Step!

Transfer time...flows quickly, comfortably and with safety on escalators with DOPPLER's Quality Assurance signature. Every transfer is not just pleasant, but also enjoyable!

Cutting edge technology, innovative, attractive designs and colors, reliable and almost silent operation, safe demarcation line and a special mechanism for quick and easy resolution of any errors are all factors which make up a perfect result.

DOPPLER's escalators minimize the distances and create "visual bridges" between different areas, since they are perfectly in line with the environment in high-rise shops, large shopping centers, airports and railway stations.

Advanced Safety Package.

Escalating Safely

Escalators are an easy and convenient way to travel from floor to floor. For DOPPLER, your safety is our first priority. With regard to our high safety standards, all our products underlie thorough tests in order to ensure a safe ride.

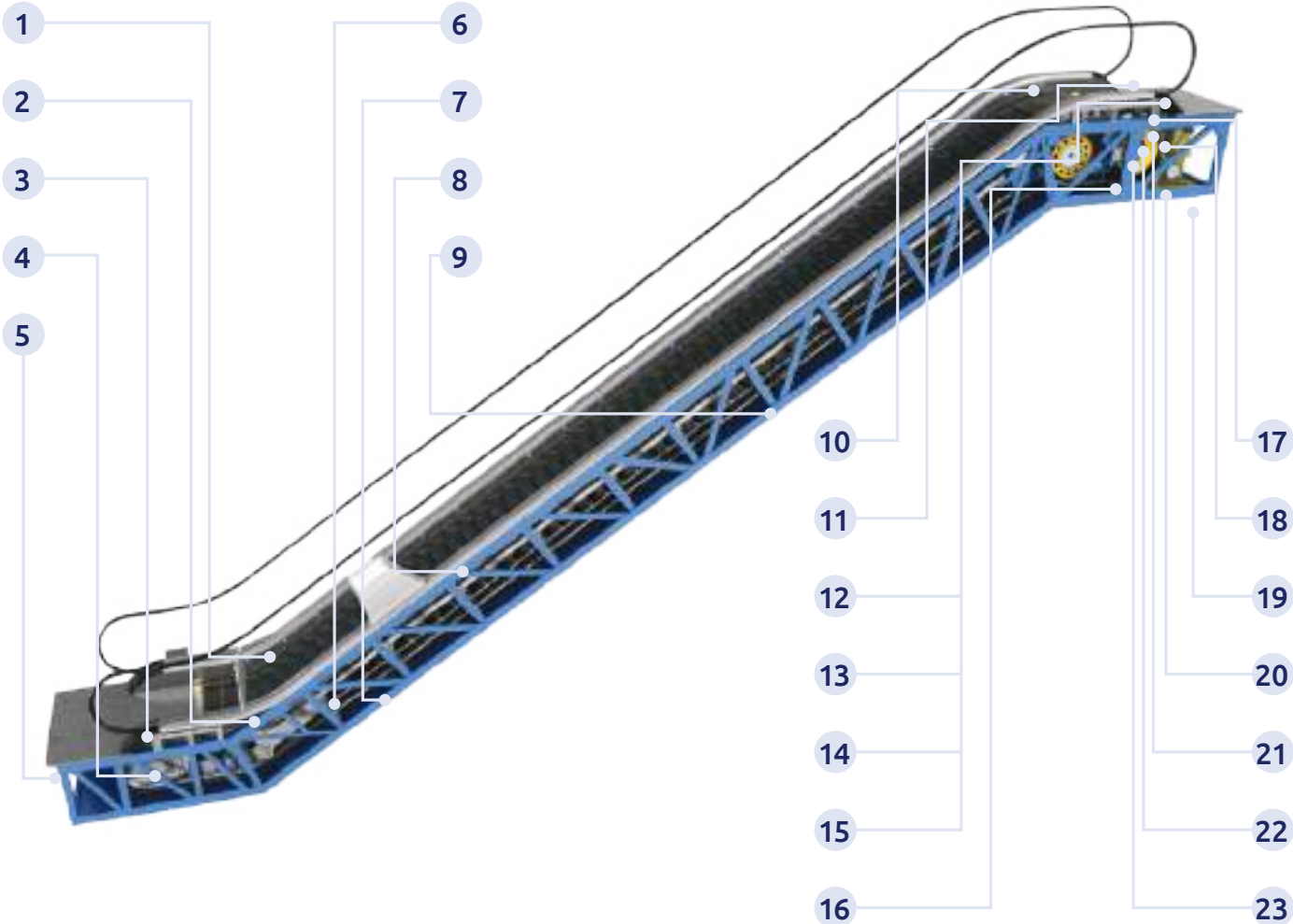

Safety Device		Standard/Optional
1	Barrier device	Standard
2	Running speed protection of hand strap	Standard
3	Protection device for the outlet and inlet of hand strap	Standard
4	Fracture protection device of step chain	Standard
5	Monitoring device of maintenance cover plate	Standard
6	Skirting panel protection device	Standard
7	Step loss protection device	Standard
8	Anti-climb device	Standard
9	Step sagging protection device	Standard
10	Emergency stop button	Standard
11	Monitoring device of maintenance cover plate	Standard
12	Failure monitor	Standard
13	Step speed monitoring device	Standard
14	Motor overload protection	Standard
15	Over-speed protection device	Standard
16	Auxiliary brake ($H \geq 6m$)	Optional
17	Comb protection device	Standard
18	Protection of phase dislocation and phase loss	Standard
19	Ground protection of safety circuit	Standard
20	Detection of water level (Outdoor)	Optional
21	Working brake	Standard
22	Unintentional reversal of the direction of travel	Standard
23	Broken drive-chain protection device	Standard

Arrangements.

Single Unit

The single unit is used to link two levels. It is suitable for buildings with passenger traffic flowing mainly in one direction. Flexible adjustment to traffic flow is possible.

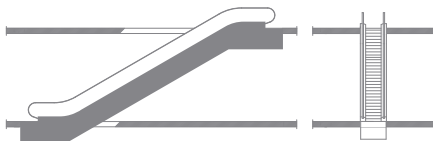

Interrupted & Parallel (one & two-way traffic)

The interrupted arrangement is somewhat inconvenient for users, but advantageous for department store owners. The parallel interrupted arrangement is used mainly in department stores and public transport buildings with a heavy traffic volume. When there are three or more escalators, it should be possible to reverse the traveling direction according to the traffic flow. This arrangement is economical, since no inner lateral claddings are required.

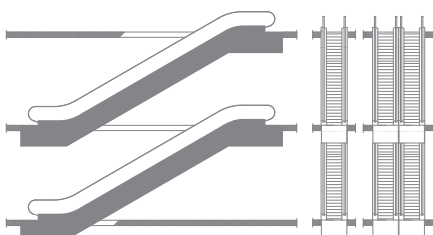

Continuous (one-way traffic)

The continuous arrangement is used mainly in smaller department stores to link three sales levels. It requires more space than the interrupted arrangement.

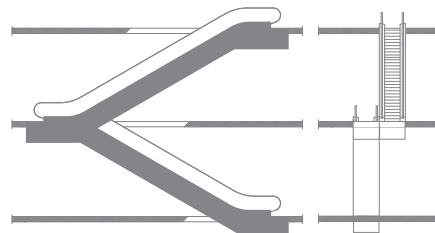



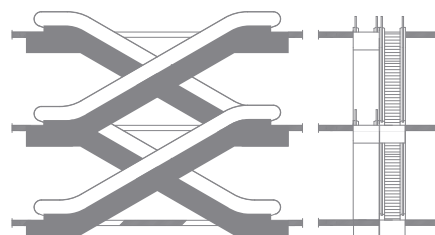

Crisscross, Continuous (two-way traffic)

The crisscross continuous arrangement is used mainly in major department stores, public buildings and public transport buildings where transport times between several levels should be kept to a minimum.







Function Configuration.

Standard Functions

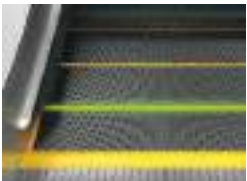
HANDRAIL OUTLET & INLET	SKIRT PANEL BRUSH	EMERGENCY STOP BUTTON	AUTOMATIC OIL SUPPLEMENT SYSTEM	PROTECTION DEVICE FOR STAIR DEFICIENCY
The elegant style of the escalator is defined from the modern structure and its robust construction.	The brushes are made with durable material, and provide a soft surface to warn passengers and encourage them to keep away from the extreme sides of the escalator, in order to avoid accidents.	In case of emergency or malfunction, the emergency stop button directly immobilizes the escalator, in order to ensure all passengers' safety.	The PCP-controlled automatic oiling and lubrication system is able to provide proper oiling to the transmission chain and thus extending the life of the mechanism.	Sensor is installed in rotation of stairs of escalator. When there is deficiency of steps, the escalator will stop operating.
				

Optional Functions

STEP BOUNDARY LIGHT	DIRECTION INDICATOR	SKIRTING PANEL LIGHTING	HANDRAIL ILLUMINATION	AUTOMATIC START/STOP
To aid passengers in clearly identifying the boundary line between steps, fluorescent lamps are mounted under the escalator steps. These are located at the upper and lower landings.	The display installed in the handrail entrance shows the running direction of the escalator in order to facilitate the transportation of passengers.	Apron lighting not only enhances the escalator's visibility in the entire building but also adds a modern touch to its appearance.	The handrail illumination has been installed in the support frame, adding gentle lighting to the moving escalator.	The infrared ray sensors are installed in the escalator aiming at starting its operation only when a passenger steps in. After the passenger steps out, the escalator stops.
				

Accessories.

Handrail Color



Black
(Standard)

Blue
(Optional)

Green
(Optional)

Gray
(Optional)

Light Brown
(Optional)

Red
(Optional)



White Lighting
(Optional)

Blue Lighting
(Optional)

Red Lighting
(Optional)

Yellow Lighting
(Optional)



Comb Teeth & Baseboard Panel Form

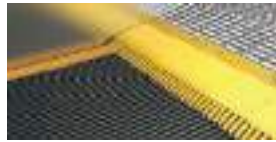

Yellow Plastic Comb Teeth (Standard)

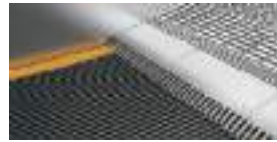

Aluminium Comb Teeth (Optional)

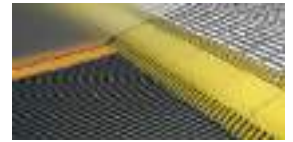

Aluminium Yellow Paint Comb Teeth (Optional)



Safety Glass (Vertical Handrail Standard)



Stainless Steel (Vertical Handrail Optional)



Stainless Steel (Oblique Inclined Handrail Standard)

Step

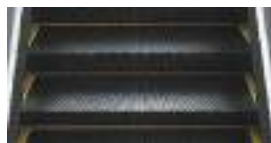

Black Stainless Steel C-Type Plastic Frame



Silver Gray Aluminium Alloy



Black Aluminium Alloy (Optional)

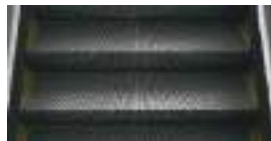

Frame Spraying C-Type (Optional)



Frame Spraying E-Type (Optional)



Frame Yellow Plastic E-Type (Optional)

Indicators, Landing Plates & Skirting Lighting



Transparent LED Plastic Display



Black Plastic Dot Matrix Display



Stainless Steel Square Patch



Aluminium Alloy Paster/Integral



White Lighting (Optional)



Blue Lighting (Optional)



Red Lighting (Optional)



Yellow Lighting (Optional)

DHS 200-30 K Commercial Escalators.

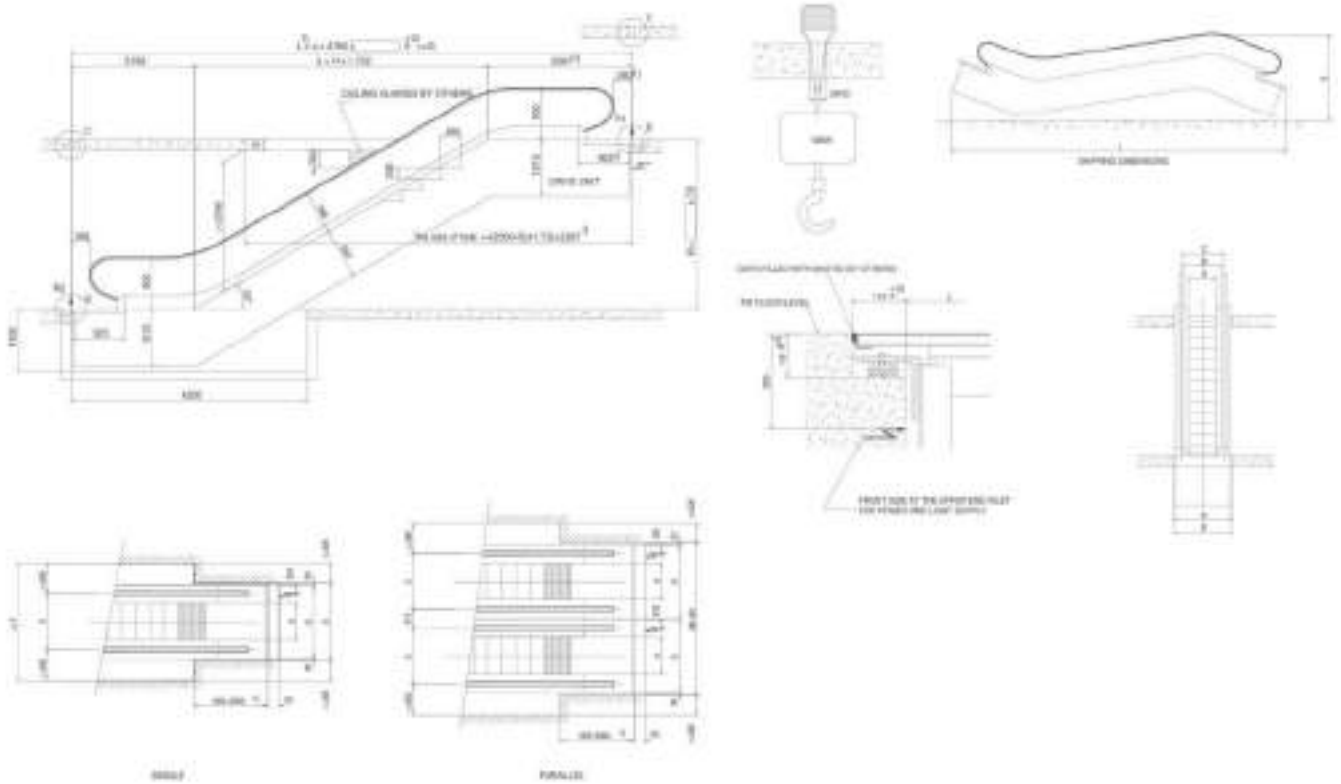

Escalator Range of Application							
Type	Rise	Weight	Support Load R1	Support Load R2	Power	Transport size	Transport size
30-60 K 3240 man/hour	H	KN	KN	KN	V=0.5 m/s	H	I
	3000	57	49	45	5.5	2171	11213
	3500	61	53	48	5.5	2216	12200
	4000	64	56	52	5.5	2252	13190
	4500	67	59	55	5.5	2282	1481
	5000	71	63	58	5.5	2307	15173
	5500	74	66	61	5.5	2328	16166
6000	77	69	64	5.5	2346	17159	
30-60 K 3240 man/hour	H	KN	KN	KN	V=0.5 m/s	H	I
	3000	59	56	51	5.5	2064	10823
	3500	63	60	55	5.5	2100	11813
	4000	66	63	59	5.5	2128	12804
	4500	70	67	63	5.5	2151	13796
	5000	73	71	66	8	2170	14789
	5500	77	75	70	8	2186	15784
6000	80	79	74	8	2200	16779	
30-100 K 6000 man/hour	H	KN	KN	KN	V=0.5 m/s	H	I
	3000	62	63	59	5.5	2064	10823
	3500	66	68	63	8	2100	11813
	4000	70	72	67	8	2128	12804
	4500	73	77	72	8	2151	13796
	5000	77	82	76	11	2170	14789
	5500	81	86	81	11	2186	15784
6000	85	91	85	11	2200	16779	

Step Width	600mm	800mm	1000mm
Step width	600	800	1000
Width between handrails	757	957	1157
Handrails center distance	837	1038	1237
Width of escalator	1140	1340	1540
Width of shaft	1180	1380	1580
Minimum spacing	1836	2036	2236
Maximum outreach	18900	17200	16000

1. If $L > G$, an intermediate support is required, please consult us.

2. If step width is 600mm, upper truss shall increase 417mm.

3. Details motor power parameters may check with our technical department.

DHS 200-30 Public Heavy Duty.

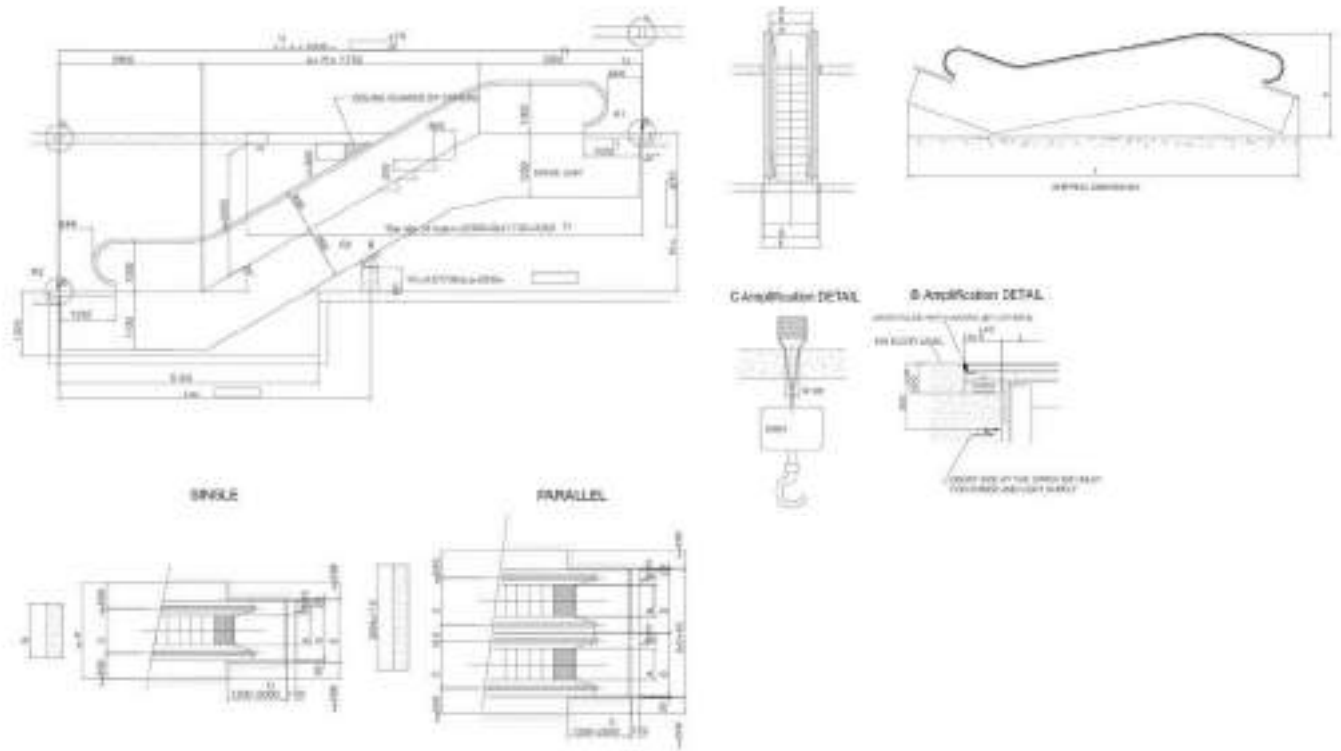

Escalator Range of Application												
Type	Rise	Weight	Power kw	Type	Rise	Weight	Power kw	Type	Rise	Weight	Power kw	
30-60 K 3240 man/hour	H	KN	V=0,5 m/s	30-80 M 4800 man/hour	H	KN	V=0,5 m/s	30-100 M 6000 man/hour	H	KN	V=0,5 m/s	
	3000	77	5.5		3000	78	5.5		3000	81	8	
	3500	80			3500	82			3500	85		
	4000	84			4000	86			4000	89		
	4500	87			4500	90			4500	93		
	5000	91			5000	93			5000	97		
	5500	94			5500	97			5500	101		
	6000	98	8		6000	101	11		6000	106	15	
	6500	101			6500	105			6500	110		
	7000	105			7000	108			7000	114		
	7500	108			7500	112			7500	118		
	8000	112			8000	116			8000	131		
	8500	115			8500	120			8500	135		
	9000	118	11		9000	123	15		9000	139	2 x 11	
	9500	122			9500	127			9500	143		
	10000	125			10000	131			10000	147		
	11000	135			11000	148			11000	155		
	12000	139			12000	155			12000	163		
13000	146	13000		163	13000	171						
14000	153	15	14000	170	2 x 11	14000	180	2 x 15				
15000	168		15000	178		15000	188					
16000	175		16000	186		16000	196					
17000	182		17000	193		17000	204					
18000	189		18000	201		18000	212					
			2 x 11				2 x 15					

Step Width	600mm	800mm	1000mm
Step width	600	800	1000
Width between handrails	757	957	1157
Handrails center distance	837	1037	1237
Width of escalator	1170	1370	1570
Width of shaft	1210	1410	1610
Minimum spacing	1836	2036	2226
Maximum outreach	18900	17200	16000
Width of supporting	1100	1300	1500

1. If $L > G$, an intermediate supprt is required, please consult us.
2. If step width is 600mm, upper truss shall increase 417mm.
3. Details motor power parameters may check with our technical department.

DHS 300 Moving Walk 10° - 12°.

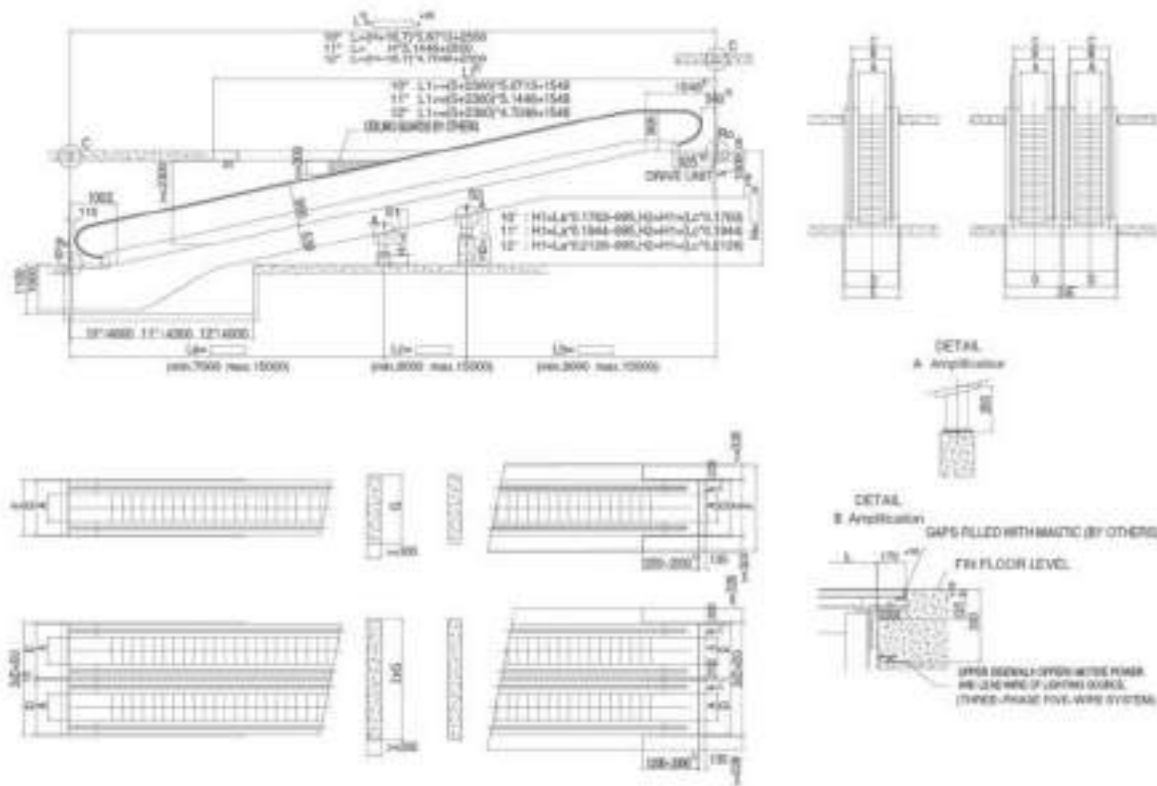

Moving Walk Range of Application							
Type	Rise		Mid - support		La	Lb	Lc
	From	To	KN	KN			
10	1273	2154	-	-	V=0,5 m/s	H	I
	2155	3388	1	-	7000	L - 7000	-
	3389	4799	1	-	L - 15000	15000	-
	4800	6000	1	1	7000	15000	L - 22000
11	1423	2394	-	-	V=0,5 m/s	H	I
	2395	3754	1	-	7000	L - 7000	-
	3755	5309	1	-	L - 15000	15000	-
	5310	6000	1	1	7000	15000	L - 22000
12	1572	2634	-	-	V=0,5 m/s	H	I
	2635	4122	1	-	7000	L - 7000	-
	4123	5822	1	-	L - 15000	15000	-
	5823	6000	1	1	7000	15000	L - 22000

Support by force			
	q	M	N
YSS80	0.0039	9.5	4.5
YSS100	0.0045	11	5

	YSS80	YSS100
A	800	1000
B	957	1157
C	1037	1237
D	1340	1540
E	1380	1580
F	2036	2236
G	1300	1500

Support		
Without mid-support	Single mid-support	Double mid-support
Ro=L*q+M	Ro=Lb*q+M	Ro=Lb*q+M
	Ru=La*q+N	Ru=La*q+N
Ru=L*q+N	S1= (La + Lb)*q*1,3	S1= (La + Lc)*q*1,3
		S2= (Lb + Lc)*q*1,3

1. Use the tread with 133 mm pitch.
2. Upper truss shall increase 417 mm for double drive.

DHS 300 Moving Walk 0°.

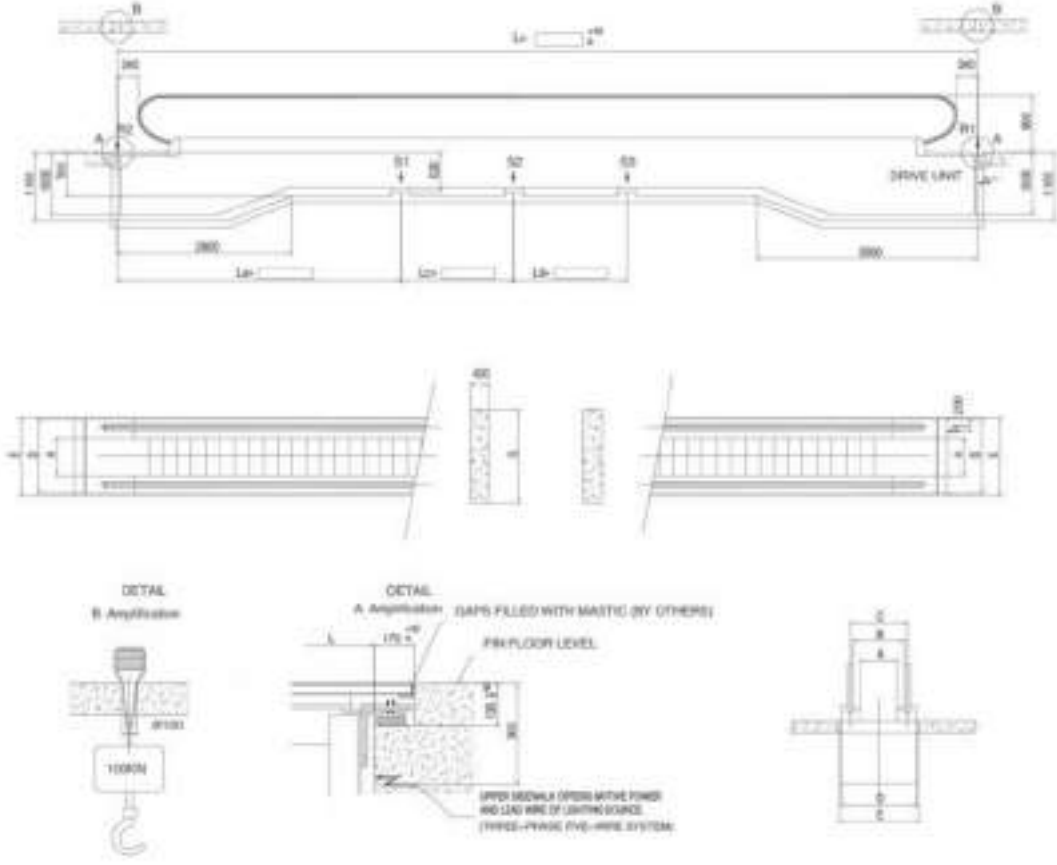

Moving Walk Range of Application		
	YSH80	YSH100
A	800	1000
B	957	1157
C	1037	1237
D	1340	1540
E	1380	1580
F	2036	2236
G	1300	1500





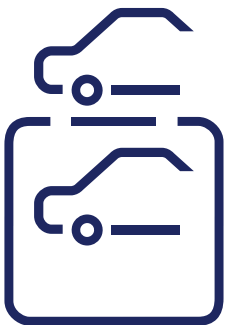

Parking Systems.

Extra Space for Parking!

Since the construction of parking spaces is necessary when designing new buildings, DOPPLER's parking systems are the best option!

They are the modern, flexible and reliable solution for shopping centers and public buildings, but also for residences.

We are equipped with state-of-the-art mechanisms, which fully optimize both, limited spaces and the available height of every building. The combination of pistons/chains with the mechanical locking system makes DOPPLER's parking systems safer and more resistant to long-term use.

Accompanied with low cost installation and environmental pollution reduction, these parking systems constitutes a reliable solution for areas with low building coefficients.

DCS-2D/2P

DCS – 2D/2P doubles the available parking space and is suitable for both enterprise and residential buildings, car dealers, rental areas and parking buildings where the long-term parking goes on the platform and the short-term parking on the space below.

It features hydraulic direct drive with multi-stage cylinder. No pit is necessary.

DCS-2D/2P is also available in multi version where it requires n+1 posts for 2*n parking spaces with an additional cost reduction, because two neighbor systems can share the same post (column).

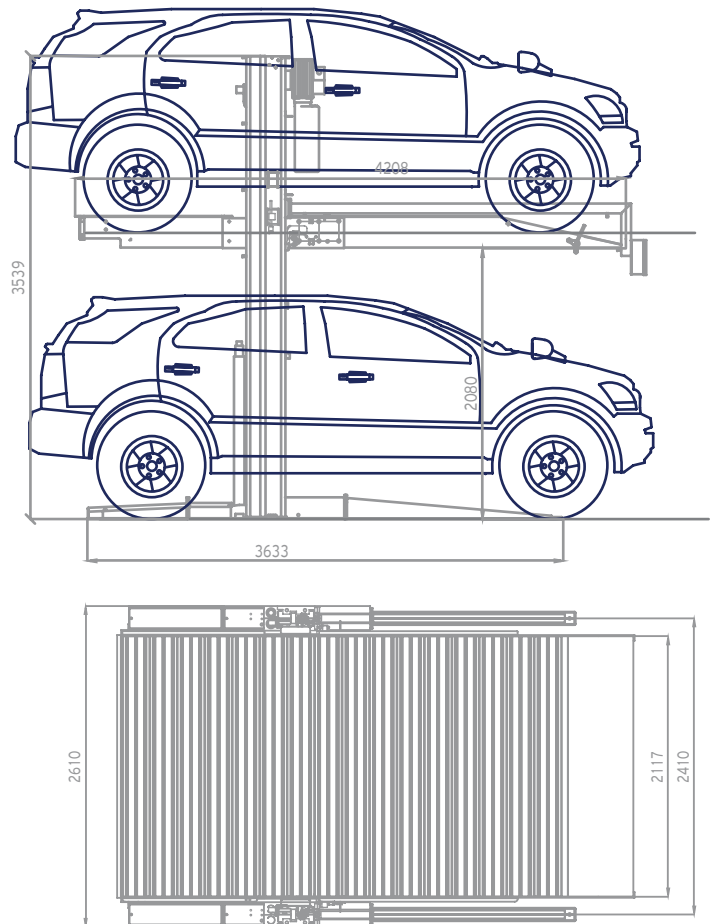

Specifications

Lifting capacity	Light Height	Runway Width	Outer Dimensions (LxWxH)	Rise/Drop Time	Power
2700 KG	1600 / 1840mm	2117mm	4256x2652x2796mm	45/40s	2.2 kw
	1600 / 1800mm	2117mm	4208x2616x3109mm	90/75s	2.2 kw
	1600 / 2100mm	2117mm	4208x2616x3539mm	95/90s	2.2 kw

DP-2I/2P

DP-2I/2P offers lower price and complete cover under the runways to protect your vehicle.

It doubles the available parking space and is suitable for office or residential buildings, car dealers or rental areas and parking buildings.
No pit is required.

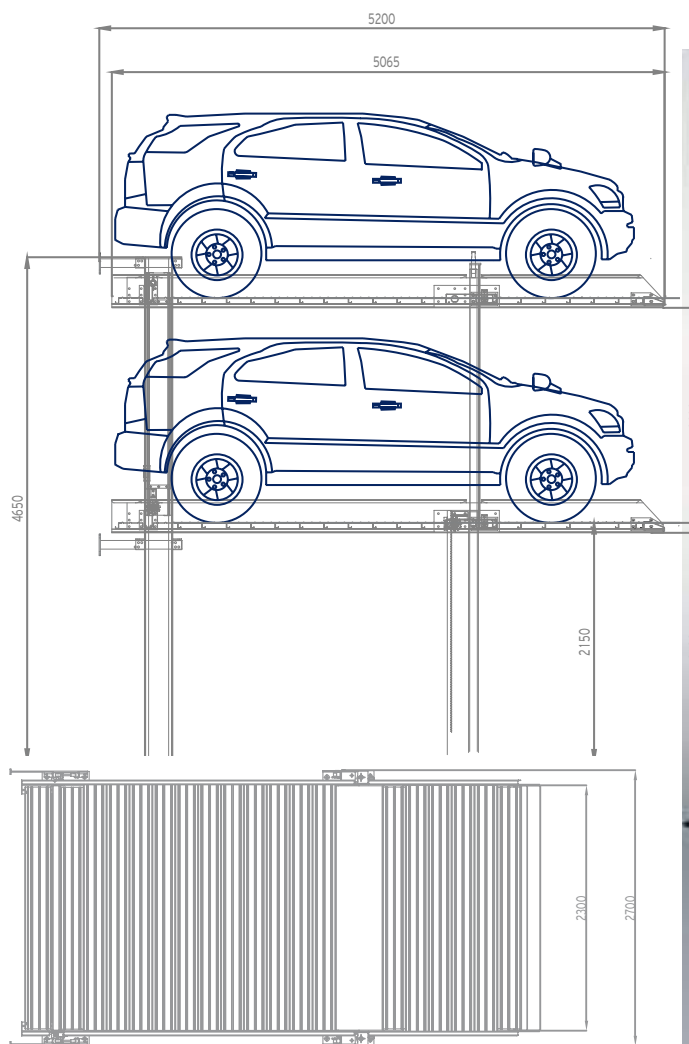

Specifications

Lifting capacity	Light Height	Runway Width	Outer Dimensions (LxWxH)	Rise/Drop Time	Power
5000 kg	1680mm	2000mm	5460x3172x2531mm	55/50s	2.2 kw
	1790mm	2095mm	5073x2378x4270mm	55/50s	2.2 kw

DCS-2DL

DCS-2DL is a smart modification of DCS-2D/2P, suitable for installations where available ceiling height is limited. These features make this product ideal for, existing buildings, as no site works are required for installation.

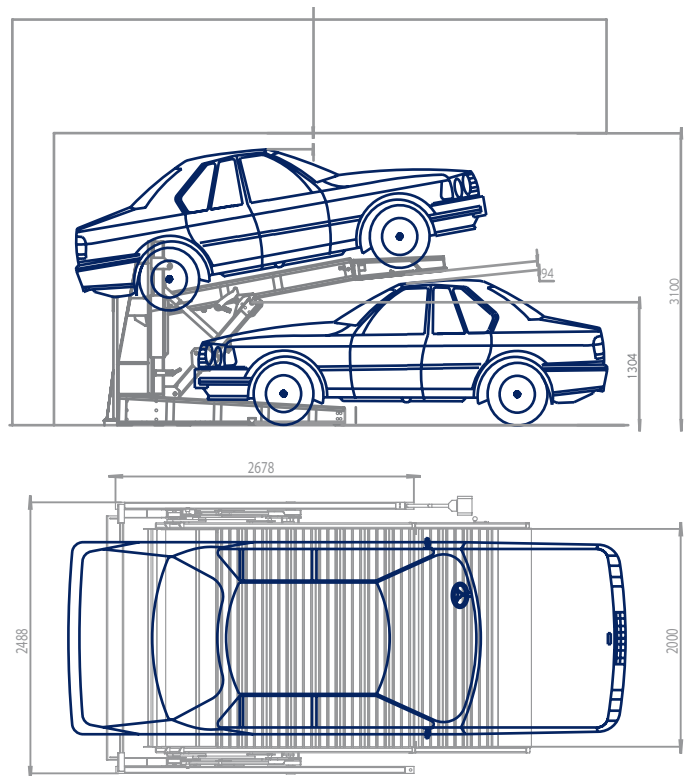

Specifications

Lifting capacity	Light Height	Runway Width	Outer Dimensions (LxWxH)	Rise/Drop Time	Power
2700 kg	1900mm	2002mm	3814x2580x1955mm	45/4s	2.2 kw

DPS-xRyC

DPS-xRyC is a puzzle parking system serving the needs of high traffic buildings (offices, parking facilities etc) where the available space is limited. It doesn't require a pit and is designed to operate in a way that ensures accessibility to all platforms automatically.

The total of serving platforms derives from $R \times C - (R - 1)$ where R represents rows and C represents columns. DPS-xRyC is a very versatile piece of machinery because it provides multiple solutions depending on the number of rows and columns selected by the customer.

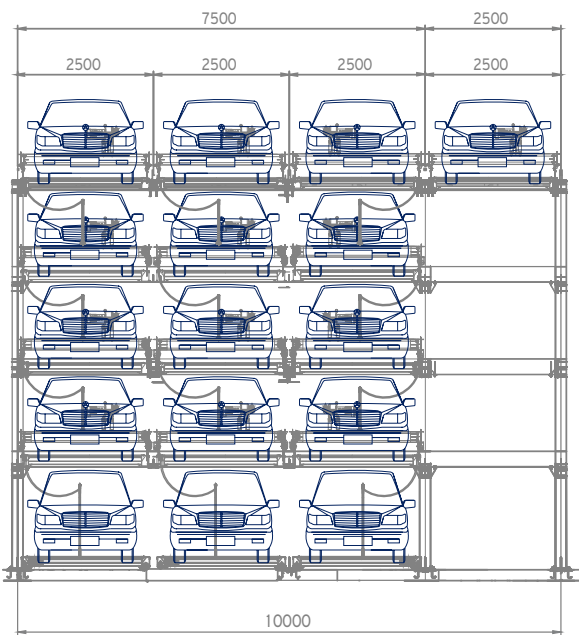

Specifications

Lifting capacity	Light Height	Runway Width	Outer Dimensions (LxWxH)	Rise/Drop Time	Power
2700 kg	1900mm	2002mm	3814x2580x1955mm	45/4s	2.2 kw

Robotic Parking Systems.

Less space..more cars.

Park easy and safe!

- ▶ Space Optimization
40-50 percent of floor space needed.
- ▶ Cost-Effectiveness
Lower land cost relative to parking places.
Lower concrete repairs and maintenance.
Lower liability insurance.
- ▶ Software Complete control by visualization program. Shorter handling time
by Smart-Path-Founder.
- ▶ Security Theft, vandalism or accidental damage eliminated. Complete
surveillance of transfer systems.
- ▶ Environmental Protection
Reduced vehicle emissions
Energy savings



Robotic Parking Systems.

DTR - Doppler Trolley System

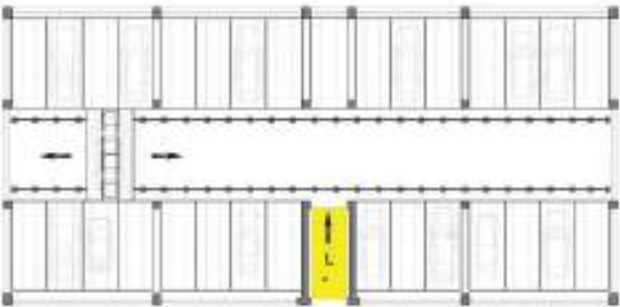

DMT - Doppler Multidimensional Trailer

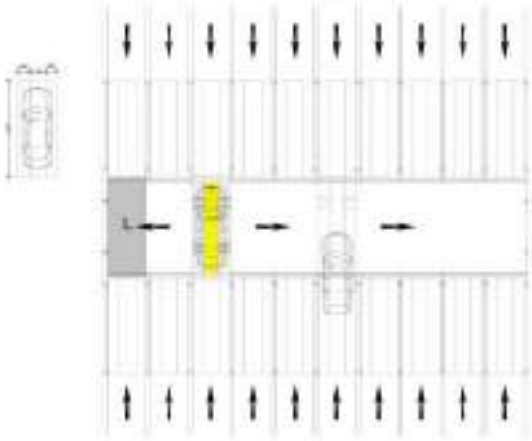



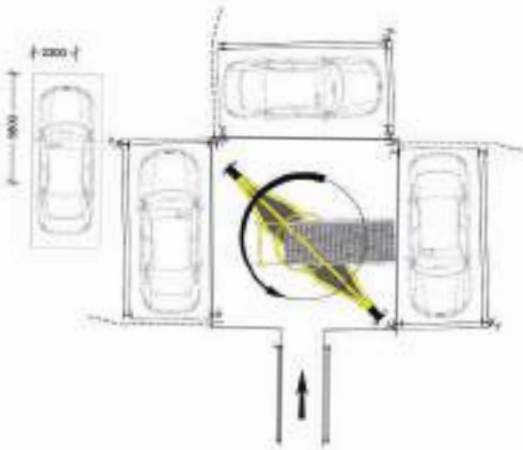

DDT - Doppler Display Tower

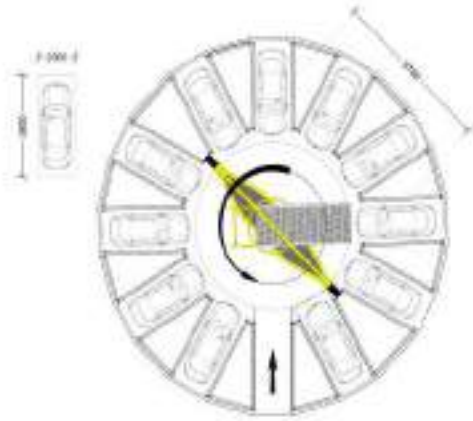

DPT - Doppler Polar Tower

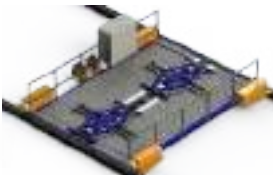

Holding Robot		Transmission	Platform	
Holding robot with opened arms	Holding robot with closed arms	Cable Reel	Central Platform for horizontal movement	
				



Inclined lifts.

Features:

Inclined lifts are tailor made to meet the individual requirements of each project and ensure the easy connection of every building level. Air conditioned and easy to use, inclined lifts provide a safe and easy transfer through levels.

- ▶ Indoor/outdoor use
- ▶ Closed cabin/platform
- ▶ Automatic / semiautomatic doors
- ▶ Up to 1m/s

Use:



Inclined lifts.



Hotels.

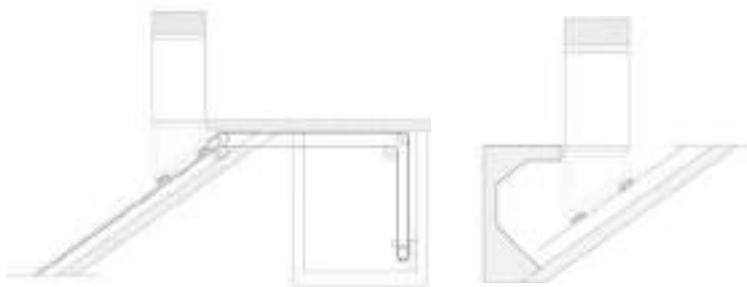

Socialize with us!

#DOPPLER_SA



Copyright © 2015-2020 by DOPPLER S.A.
All rights reserved. No part of this publication may be reproduced, distributed, or transmitted in any form or by any means, including photocopying, recording, or other electronic or mechanical methods, without the prior written permission of the publisher. Except in the case of brief quotations embodied in critical reviews and certain other noncommercial uses permitted by copyright law.

Graphic Design: Doppler S.A.

Photos may differ slightly in appearance from reality.
Materials may change without any prior notice.

DOPPLER
Elevating your World.

GREECE

HEAD OFFICES - FACTORY

Polykastro Industrial Park
61200 Polykastro, Greece
T. +30 23430 54000
F. +30 23430 23701
E. info@doppler.gr

ATHENS BRANCH

12, Lassani str, Peristeri
12132 Athens, Greece
T. +30 210 3416210
F. +30 210 3416474
E. infoath@doppler.gr

CHINA

DOPPLER ELEVATOR CO.,LTD

No.1185, Second Section of Huafu Avenue
Shuangliu, 610213, Chengdu, Sichuan
T. +86 28 61906123
F. +86 28 61906100
E. office@doppler.net.cn

CYPRUS

DOPPLER MANUFACTURERS LTD

Christodoulou Sozou 2
1096 Nicosia, Cyprus
T. +357 99 616123
E. info@doppler.gr

ITALY

DOPPLER SRL

Via G. Marconi 2, Milan
20010 Pogliano Milanese (MI), Italy
T. +39 02 93291421
F. +39 02 93291421
E. info@doppleritalia.it



Elevating your World.

In more than 65 countries!

For more information about DOPPLER S.A. visit our website or simply scan the QR Code.



DOPPLER

www.doppler.gr